

rada

CONTROLS

320 Series

Australian

PRODUCT MANUAL

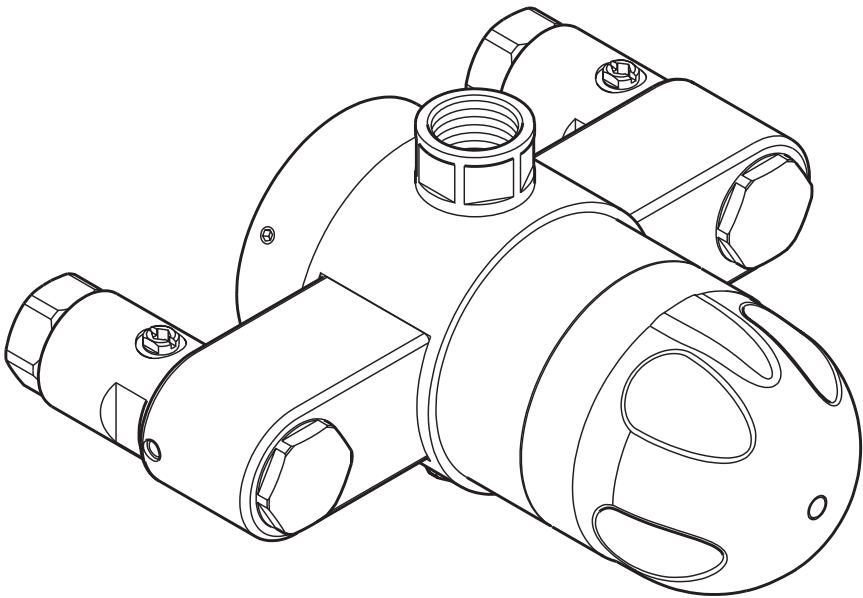

IMPORTANT

Installer: This manual is the property of the customer and must be retained with the product for maintenance and operational purposes.

INDEX

INTRODUCTION	3
DESCRIPTION	3
SAFETY WARNINGS	3
ADVICE	4
PACK CONTENTS	5
DIMENSIONS	7
SPECIFICATION	9
INSTALLATION	12
COMMISSIONING	14
OPERATION	17
FAULT DIAGNOSIS	18
MAINTENANCE	20
SPARE PARTS	32
CUSTOMER CARE	Back Cover

INTRODUCTION

The Rada 320-t3 Thermostatic mixing valve is specified to meet the highest standards of safety, comfort and economy as demanded by today's users. The Rada 320 is designed, manufactured and supported in accordance with accredited BS EN ISO 9001:1994 Quality Systems.

DESCRIPTION

3/4" thermostatic mixing valves to suit a wide diversity of applications and installation formats.

Incorporates the Radatherm cartridge, a unique sealed-for-life unit utilising proven durability high-technology materials for extended service-free reliability. This cartridge employs the advanced 2nd generation 'thermoscopic' temperature sensor to provide water at safe, accurate temperatures for showering or process requirements.

Product Range

Rada 320-t3 cx Aus - For connection to surface pipework, includes angled checkvalve elbows with integral isolating ball valves. Polished chrome temperature knob, body and fittings.

Rada 320-t3 oem Aus - Designed to be used in conjunction with building-in boxes and duct installations, the 320-t3 oem Aus features 3/4" - 1" BSP male checkvalve adapters. Polished chrome temperature knob and body.

SAFETY WARNINGS

The function of this thermostatic mixing valve is to deliver water consistently at a safe temperature. This requires that:

1. It is installed, commissioned, operated and maintained in accordance with the recommendations given in this Manual.
2. Type 3 valves are only used for applications covered by their approved designations.
3. Periodic attention is given, as necessary, to maintain the product in good functional order. Recommended guidelines are given in the **MAINTENANCE** section.

4. This product is not used in conditions outside the specification limits given in this Manual.

The following statement is a requirement of Standards Australia:

"This valve is intended mainly for use in applications with a set temperature below 45°C. When installed at higher set temperatures, the performance may be less than that specified in AS 4032.1. In such situations consideration should be given to the question of whether an alternative device, i.e. a tempering valve approved to AS 4032.2 would provide a greater margin of safety in preventing scalding accidents".

ADVICE

The use of the word 'failsafe' to describe the function of a thermostatic mixing valve is both incorrect and misleading. In keeping with every other mechanism it cannot be considered as being functionally infallible.

Provided that the thermostatic mixing valve is installed, commissioned, operated within the specification limits and maintained according to this Manual, the risk of malfunction, if not eliminated, is considerably reduced.

Malfunction of thermostatic mixing valves is almost always progressive in nature and will be detected by the use of proper temperature checking and maintenance routines.

Certain types of system can result in the thermostatic mixing valve having excessive 'dead-legs' of pipework. Others allow an auxiliary cold water supply to be added to the mixed water from the mixing valve. Such systems can disguise the onset of. Ultimately, the user or attendant must exercise due diligence to ensure that the delivery of warm water is at a stable, safe temperature. This is particularly important in such healthcare procedures as supervised bathing of patients unable to respond immediately to unsafe temperatures. thermostatic mixing valve malfunction.

PACK CONTENTS

Tick the appropriate boxes to familiarize yourself with the part names and to confirm that the parts are included.

Rada 320-t3 cx Aus

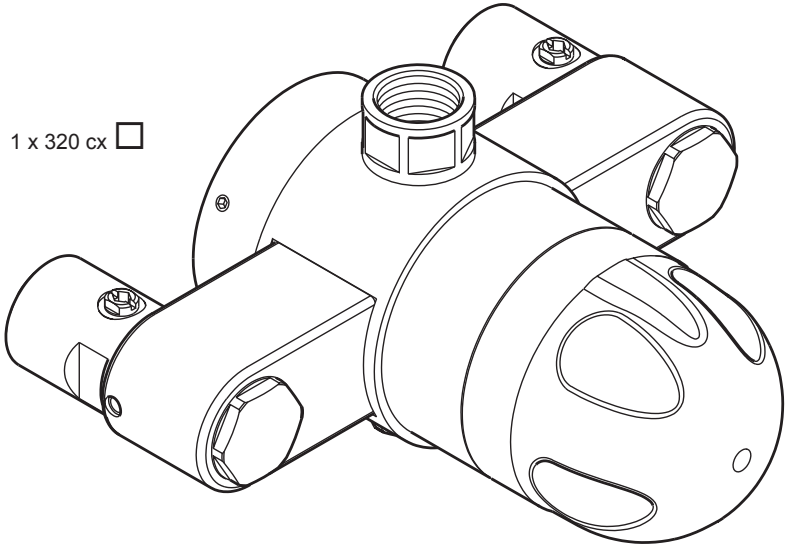

1 x 3 mm
Hexagonal Wrench

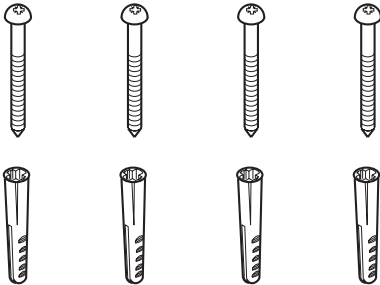

1 x Concealing Cap

4 x Screws

4 x Wall Plugs

1 x Product Manual

Rada 320-t3 oem Aus

Tick the appropriate boxes to familiarize yourself with the part names and to confirm that the parts are included.

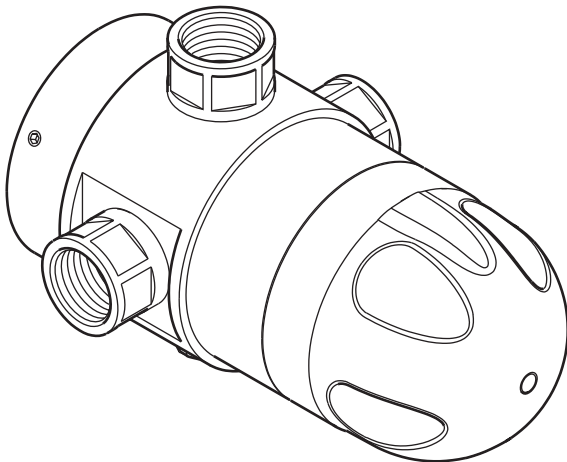

1 x 320 oem

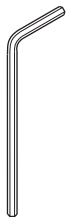

1 x 3 mm
Hexagonal Wrench

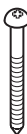
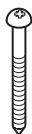

 1 x Concealing Cap

4 x Screws



4 x Wall Plugs

1 x Product Manual

DIMENSIONS

Rada 320-t3 cx Aus

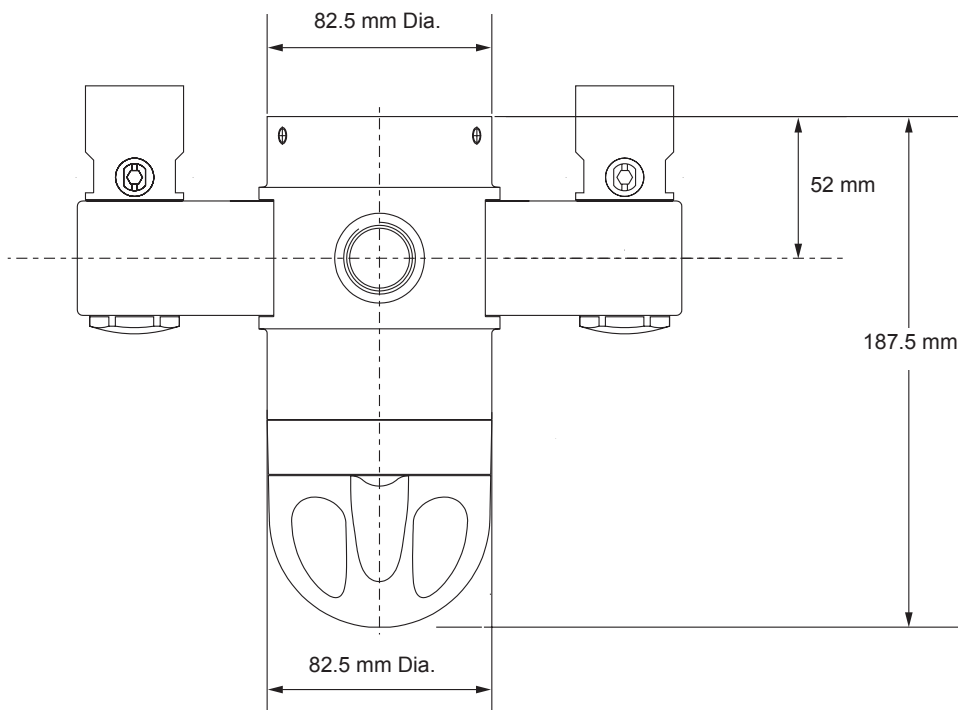
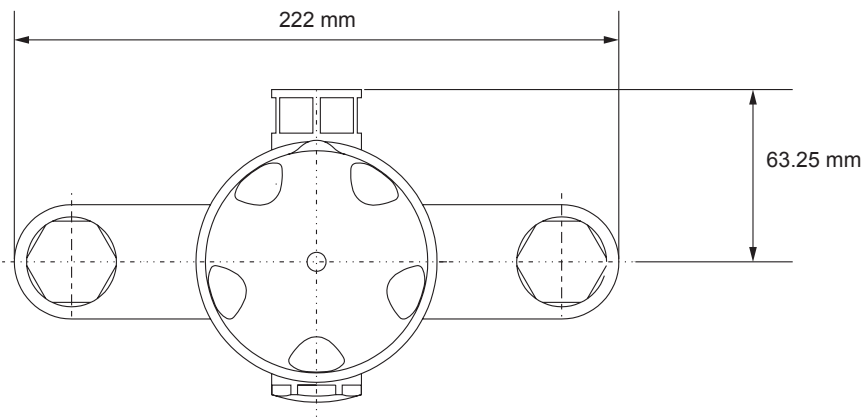

Rada 320-t3 oem Aus

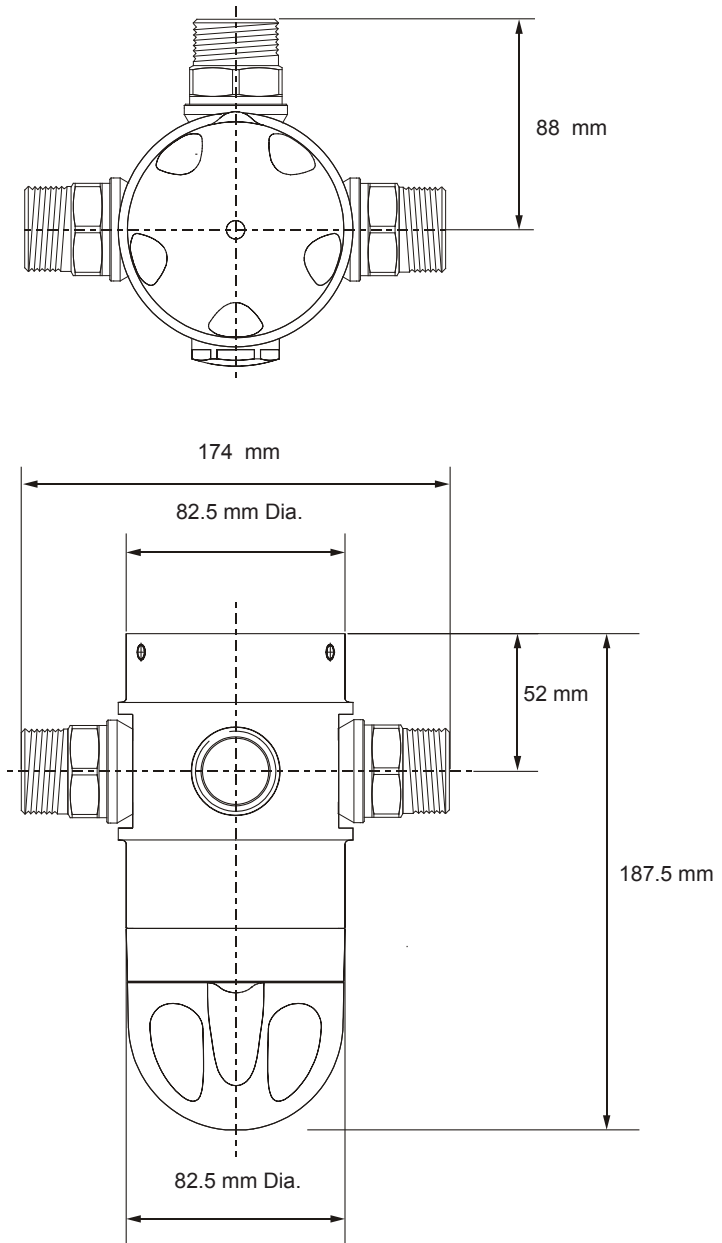

SPECIFICATION

Normal Operating Conditions are considered as:

- inlet dynamic pressures nominally balanced to within 10% of each other during flow.
- a differential of approximately 50°C between the hot and cold inlet temperatures, and with differentials of 15-35°C between the blend setting and either supply.
- daily usage of 1-6 hours.
- installation and usage environment not subject to extremes of temperature, unauthorised tampering or wilful abuse.

Other Applications

For information on other specific applications or suitability, refer to H. G. Thornthwaite Pty Ltd or Mira Showers.

Disinfection

In applications where system chemical disinfection is practised, chlorine can be used (calculated chlorine concentration of 50 mg/l (ppm) maximum in water, per one hour dwell time, at service interval frequency). Such procedures must be conducted strictly in accordance with the information supplied with the disinfectant and with all relevant Guidelines/Approved Codes of Practice.

If in any doubt as to the suitability of chemical solutions, refer to H. G. Thornthwaite or Rada Controls.

Pressures and Flow Rates

For optimum performance, dynamic supply pressures should be nominally equal.

Recommended Minimum Flow Rate: 6 l/min at mid-blend with equal dynamic supply pressures.

Recommended Maximum Flow Rate: 120 l/min at mid-blend (which equates to a maximum pressure loss of 560 kPa [5.6 bar]).

Note! 1 bar = 100 kPa

Maximum Pressure Loss Ratio*: should not exceed **10:1**, in favour of either supply, during flow.

Recommended Minimum Dynamic Supply Pressure: 15 kPa - 20 kPa healthcare (0.15 / 0.2 bar)

Recommended Maximum Dynamic Supply Pressure: 800 kPa (8 bar)*

Maximum Static Supply Pressure: 1000 kPa (10 bar).

* *Pressure Loss Ratio is determined by subtracting the resistance to flow of the outlet pipework and outlet fittings (generally known as "back pressure", and measured at the outlet of the mixing valve) from the dynamic pressures of the hot and cold water at each inlet of the mixing valve. This is at its extreme when the mixing valve is being used at its lowest flow-rate and when the maximum inequality occurs in the pressure of the hot and cold water supplies.*

* *If either of these values is likely to be exceeded then a drop tight pressure reducing valve must be fitted.*

Flow Rate/Pressure Loss Graph

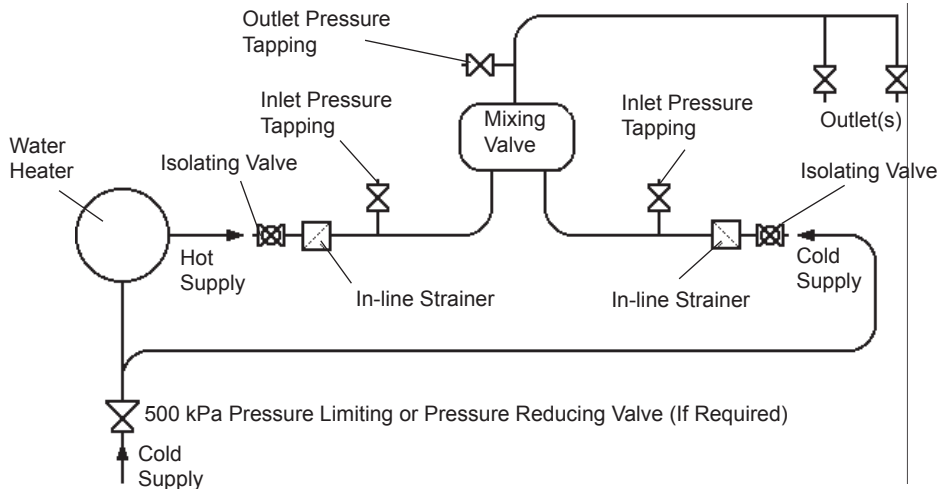
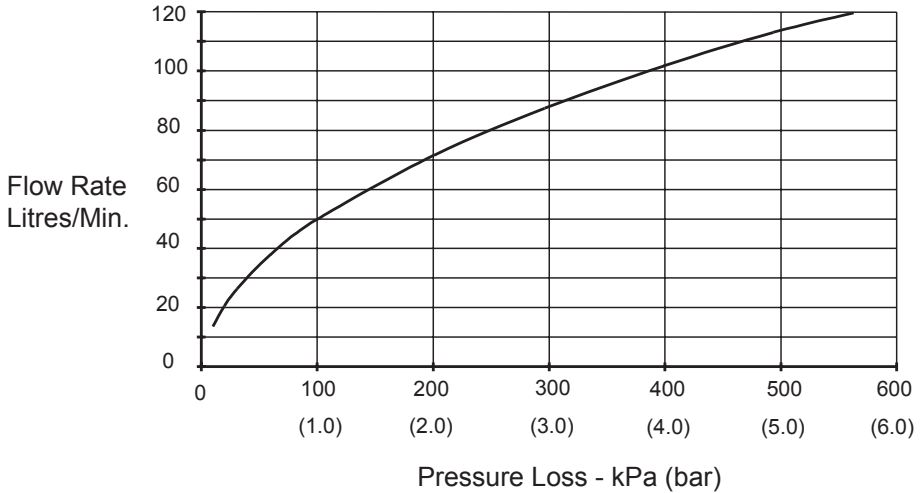

Positions Of Additional Installation Features (If Required)

Temperatures

Optimum performance is obtained when **temperature differentials of 20°C** or more exist between blend and either supply. Blend control accuracy will begin to diminish at temperature differentials below **12°C**.

Blend Temperature Range: between ambient cold and approximately 60°C, according to hot water supply temperatures.

Thermostatic Control Range: approximately 25-60°C.

Optimum Thermostatic Control Range: 35 - 46°C.

Recommended Minimum Cold Water Supply Temperature: 1°C.

Recommended Maximum Cold Water Supply Temperature: Mixed Water Temperature less 15°C.

Recommended Minimum Hot Water Supply Temperature: Mixed Water Temperature plus 15°C.

Recommended Maximum Hot Water Supply Temperature: 85°C.

Note! If the hot water supply system does not incorporate safety devices (e.g. non self resetting thermal cut out) to prevent this temperature being exceeded then the use of a tempering valve may be considered to limit the temperature of the water supplied to the mixing valve. The output temperature of this tempering valve must be set to a value not less than 60°C and it must not exceed 85°C if the hot water supplied to it reaches the maximum possible value which may occur under fault conditions in the hot water apparatus.

Flow Control

Rada 320-t3 series mixing valves do not have integral flow control; appropriate provision must be made for this in the outlet pipework.

This can be in the form of a stopcock, mechanical timed-flow controller, solenoid or basin/bath tap.

The device chosen must be non-concussive in operation.

Connections

320-t3 cx Aus Inlets: 3/4" BSP female thread
Outlet: 3/4" BSP female thread

320-t3 oem Aus Inlets: 1" BSP male thread
Outlet: 1" BSP male thread

Standard Inlet Configuration

hot - left (marked red)

cold - right (marked blue)

INSTALLATION

General

Installation must be carried out in accordance with these instructions, and must be conducted by designated, qualified and competent personnel.

1. Before commencing, ensure that the installation conditions comply with the information given in **SPECIFICATION**.
2. Care must be taken during installation to prevent any risk of injury or damage.
3. Installations must comply with all Local/National Water Supply Authority Regulations/Byelaws and Building and Plumbing Regulations.
4. The mixing valve should be positioned for easy access during use and maintenance. All routine maintenance procedures can be conducted with the mixing valve body in place. For all models, allow a minimum 100 mm clearance in front of the temperature control to enable removal of the cartridge assembly during maintenance.
5. Conveniently situated isolating valves must be provided for maintenance (not applicable for cx version as isolators are supplied).
6. The use of supply-line or zone strainers will reduce the need to remove debris at each mixing valve point. The recommended maximum mesh aperture dimension for such strainers is 0.5 mm.
7. Inlet and outlet pressure tappings should be provided to enable continuing accurate assessment of operating conditions. This is especially important in healthcare applications.
8. Pipework must be rigidly supported.
9. Pipework dead-legs should be kept to a minimum.
10. Supply pipework layout should be arranged to minimise the effect of other outlet usage upon the dynamic pressures at the mixing valve inlets.
11. Inlet and outlet threaded joint connections should be made with PTFE tape or liquid sealant. Do not use oil-based, non-setting jointing compounds.
12. **To eliminate pipe debris it is essential that supply pipes are thoroughly flushed through before connection to the mixing valve.**
13. Inlet isolators must be used in the fully open position.
14. Do not install the Rada 320 valve in a position where it may become frozen.

Outlet Position/Reversed Inlets

All Rada 320 series mixing valves are supplied with the inlet connections configured **hot - left, cold - right, and top outlet** as standard.

Should the existing hot and cold pipework make this configuration inconvenient then remove the cartridge assembly and turn it through 180° (refer to **MAINTENANCE** for cartridge removal and re-assembly).

If a bottom outlet position is required, remove the blanking cap from the bottom of the valve and replace it with the fitting from the top of the valve. Then fit the blanking cap to the top of the valve.

Installation: Rada 320-t3 cx Aus

1. Loosen the backplate grub screws (3 off) using the 3 mm hexagonal wrench (supplied) and remove the backplate.
2. Fit the backplate securely to the wall surface using the fixing screws and wall plugs provided.
3. **Important! Flush through the hot and cold supplies thoroughly before connection to mixing valve.**
4. Fit the valve onto the backplate and tighten the grub screws (3 off).
5. Connect the hot, cold and outlet pipework.
6. Check that all connections are watertight.
7. The maximum temperature will now need resetting. Refer to **COMMISSIONING**.

Installation: Rada 320-t3 oem Aus

1. Loosen the backplate grub screws using the 3 mm hexagonal wrench (supplied) and remove the backplate.
2. Where the installation requires the use of a backplate, fix it securely to the wall surface using the fixing screws and wall plugs provided.
3. Strainers should be fitted into the pipework.
4. **Important! Flush through the hot and cold supplies thoroughly before connection to the valve.**
5. Where applicable, fit the valve onto the backplate and tighten the grub screws.
6. Connect the hot and cold supplies using suitable fittings (not supplied) and check for any leaks.
7. Connect the outlet pipework.
8. Check that all connections are watertight.
9. The maximum temperature will now need resetting. Refer to **COMMISSIONING**.

COMMISSIONING

Commissioning must be carried out in accordance with these instructions, and must be conducted by designated, qualified and competent personnel.

Exercising the Thermostat

Thermostatic mixing valves with wax thermostats are inclined to lose their responsiveness if not used. Valves which have been in storage, installed but not commissioned, or simply not used for some time should be exercised before setting the maximum temperature or carrying out any tests.

A simple way to provide this exercise is:

- (a) ensure that the hot and cold water are available at the valve inlets, and the outlet is open.
- (b) move the temperature control rapidly from cold to hot and hot back to cold several times, pausing at each extreme.

Maximum Temperature

The maximum blend temperature obtainable by the user should be limited, to prevent accidental selection of a temperature which is too hot.

All Rada Thermostatic mixing valves are fully performance tested individually and the maximum temperature is pre-set to approximately 43°C under ideal installation conditions at the factory.

Site conditions and personal preference may dictate that the maximum temperature has to be re-set following installation.

Maximum Temperature Setting

Check that an adequate supply of **hot** water is available at the hot inlet of the mixing valve.

The minimum temperature of the hot water must be at least 15 °C above the desired blend, however, during resetting this should be close to the typical storage maximum to offset the possibility of any blend shift due to fluctuating supply temperatures.

Check that both inlet isolating valves are fully open (Rada 320-t3 cx Aus only).

Temperatures should always be recorded using a thermometer with proven accuracy.

For Adjustable Temperature

1. Remove the temperature knob concealing cap, then the screw using the 3 mm hexagonal wrench (supplied). Remove the temperature knob.

2. Pull off the hub.
3. Rotate the spindle until required maximum blend temperature is obtained at outlet point (**clockwise = decrease temperature, anticlockwise = increase temperature**).

When resistance is felt do not use force to turn any further, as this can damage the internal parts.

4. Once the desired maximum blend temperature is achieved, re-fit the hub without disturbing the spindle: Position the hub so that the hub stop comes up against the cartridge stop (refer to **Figure 2**) preventing any further rotation in an anti-clockwise direction. Check that blend temperature has not altered.
5. Refit the temperature knob. Make sure that the indicator points to 9 o'clock.

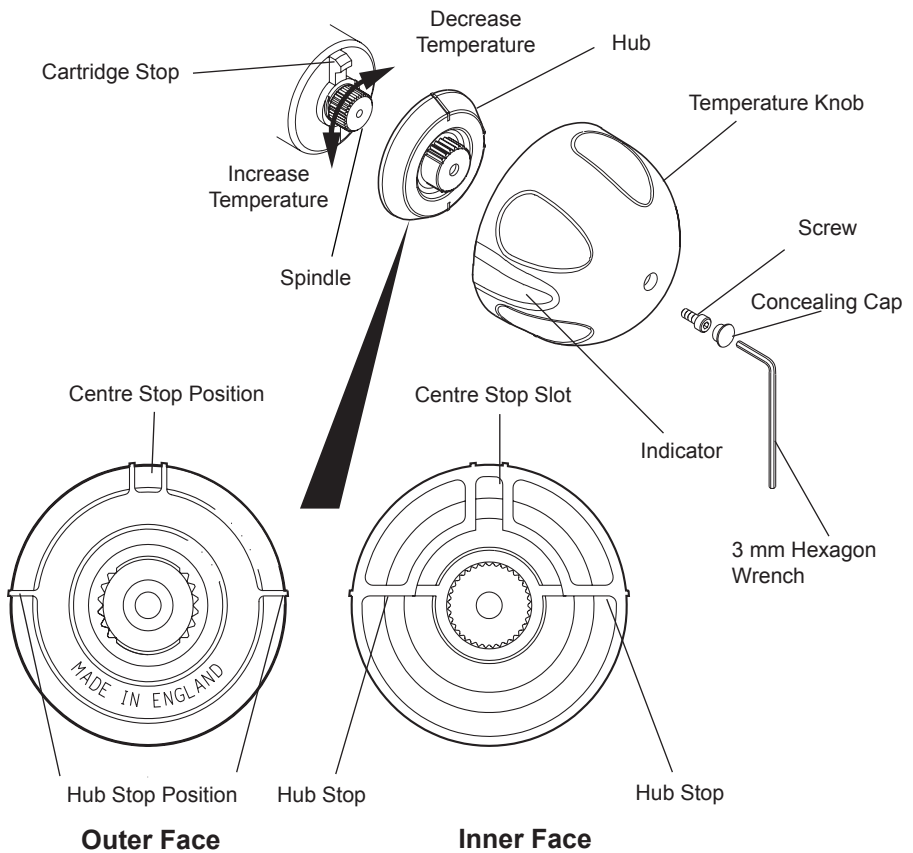

**Commissioning
Figure 2**

For Locked Temperature

1. Remove the temperature knob concealing cap, then the screw using the 3 mm hexagonal wrench (supplied).
2. Pull off the hub.
3. Rotate the spindle until required maximum blend temperature is obtained at outlet point (**clockwise = decrease temperature, anticlockwise = increase temperature**).

When resistance is felt do not use force to turn any further, as this can damage the internal parts.

4. Once the desired maximum blend temperature is achieved, re-fit the hub without disturbing the spindle, positioning it so that the centre stop slot in the hub fits over the top of the cartridge stop (refer to **Figure 2**), preventing any further rotation in either direction. Check that the blend temperature has not altered.
5. Refit the temperature knob. Make sure that the indicator points to 6 o'clock.

Commissioning Checks

(Temperatures should always be recorded with a thermometer with proven accuracy).

1. Check inlet pipework temperatures for correct function of checkvalves i.e. that hot water does not cross flow into the cold supply and vice versa.
2. Check that the supply pressures are within the range of operating pressures for the valve.
3. All connections and the mixer body are water tight.
4. Exercise the thermostat.
 - (a) ensure that the hot and cold water are available at the valve inlets, and the outlet is open.
 - (b) move the temperature control rapidly from cold to hot and hot back to cold several times, pausing at each extreme.
5. Adjust the temperature of the mixed water in accordance with the instructions (refer to **Maximum Temperature Setting**).
6. Operate the outlet flow control and check:
 - (a) Flow rate is sufficient for the purpose
 - (b) Temperature(s) obtainable are acceptable.

It is advisable to establish a performance check at this time, which should be noted for future reference as part of a Planned Maintenance Programme. The procedure should be chosen to imitate both typical and difficult operating conditions, such as any supply pressure fluctuations that may be likely. An ideal method is to locate another outlet on the common cold water supply close to the mixing valve (operating this outlet should cause a drop in supply pressure), and note the subsequent effect on blend temperature (should be no more than 2°C change).

OPERATION

For models with knob fitted for adjustable temperature control, adjustment of blend temperature from preset maximum to cold is achieved by clockwise rotation of the knob.

For models with locked temperature control, no user adjustment is intended.

Control of flow is via separate outlet valve(s), refer **Flow Control**.

FAULT DIAGNOSIS

Symptom	Cause/Rectification
<p>1. Only hot or cold water from outlet.</p>	<p>a. Inlet supplies reversed (i.e. hot supply to cold inlet). Check.</p> <p>b. No hot water reaching mixing valve. Check</p> <p>c. Check filters and inlet fittings for blockage.</p> <p>d. Refer symptom 5 below.</p> <p>e. Installation conditions continuously outside operating parameters: refer to SPECIFICATION and 2e below.</p>
<p>2. Fluctuating or reduced flow rate.</p>	<p>Normal function of mixing valve when operating conditions are unsatisfactory.</p> <p>a. Check filters and inlet/outlet fittings for flow restriction (check isolators are fully open).</p> <p>b. Ensure that minimum flow rate is sufficient for supply conditions.</p> <p>c. Ensure that dynamic inlet pressures are nominally balanced.</p> <p>d. Ensure that inlet temperature differentials are sufficient.</p> <p>e. (subsequent to rectification of supply conditions) Check thermostatic performance; renew cartridge assembly if necessary.</p>
<p>3. No flow from mixing valve outlet.</p>	<p>Check inlet isolators are fully open.</p> <p>a. Check filters and inlet/outlet fittings for blockage.</p> <p>b. Hot or cold supply failure; thermostat holding correct shutdown function: rectify, and return to 2e above.</p>
<p>4. Blend temperature drift.</p>	<p>Indicates operating conditions changed.</p> <p>a. Refer to symptom 2 above.</p> <p>b. Hot supply temperature fluctuation (rectify and refer to COMMISSIONING).</p> <p>c. Supply pressure fluctuation (refer to INSTALLATION; General).</p>
<p>5. Hot water in cold supply or vice versa.</p>	<p>Indicates check valves require maintenance, refer to MAINTENANCE.</p>

(Continued)

(Continued)

Symptom	Cause/Rectification
6. Maximum blend temperature setting too hot or too cool.	a. Indicates incorrect temperature setting ; refer to COM-MISSIONING . b. As symptom 4 above. c. As symptom 5 above.
7. Water leaking from valve body.	Seal(s) worn or damaged. a. Obtain Seal Pack, and renew all seals. b. If leak persists from around temperature spindle, renew cartridge assembly.

MAINTENANCE

General

1. The maintenance of this product must be carried out in accordance with instructions given in this Manual, and must be conducted by designated, qualified and competent personnel.
2. Rada products are precision-engineered and should give continued superior and safe performance, provided:
 - They are installed, commissioned, operated and maintained in accordance with the recommendations stated in this Product Manual.
 - Periodic attention is given as necessary to maintain the product and its associated installation components in good functional order. Guidelines are given below.
3. The use of main supply-line or zone strainers (recommended maximum mesh aperture dimension is 0.5 mm) will reduce the need to remove debris at each mixing valve point.

All the mixing valves in this series have functional parts (except the temperature or locking knob) contained within service-free cartridges, so any maintenance requirement is reduced to temperature, performance and functional checks and inspection, with cartridge renewal when necessary. In larger installations with a number of mixing valves, it is good policy to maintain a small stock of spare cartridges so that no mixing valve or facility need to be out of commission for more than the time it takes to exchange the cartridge, and also, eventually, a rolling programme of cartridge renewal can be undertaken as part of a planned maintenance procedure.

Planned Maintenance Programmes (Preventative/Precautionary Maintenance)

1. The frequency and extent of attention required will vary according to prevailing site and operational conditions. In applications (such as non-healthcare) where the risks to the user are too slight to justify the full in-service test procedure and maintenance logging process, the procedure under Performance check is suggested to cover average duty and site conditions. In all other cases it is recommended that a routine of preventative maintenance be employed which is based upon assessment of the risks to the user. The following practices are intended to support such a routine:
 - In-service tests
 - Regular temperature checking in between In-service tests
 - Maintenance of a log of In-service tests and temperature checks together with details of cartridge replacements and any other service work.

2. Thermostatic mixing valves only operate correctly when all components have been serviced and have been tested for correct performance. If any component is faulty, including the thermostat, the mixing valve will not operate correctly and could allow full hot water to pass through the mixing valve.
3. As with all other thermostatic mixing valves, the critical sensing element in the Rada 320 together with other "critical components" will exhibit wear over a period of time and usage. All of these parts are contained within the thermostatic cartridge.

4. Cartridge Replacement

- **The designed minimum service life of the thermostatic cartridge is five years, providing the Rada 320 is operated with the recommended operating conditions and within the recommended operating parameters. Therefore under these normal conditions and/or parameters it is recommended that the cartridge be replaced every five years.**

However when supply conditions and/or usage patterns do not conform to the recommended conditions and/or parameters, the cartridge may need to be changed more frequently, "recommended operating conditions" and "recommended parameters" are defined on page 9 of this product manual under the headings of 'normal operating conditions' and 'operating parameters'.

- Should an internal malfunction occur then this will probably require cartridge renewal. The thermostatic and check-valve cartridges contain no user-serviceable parts, and must not be dismantled. Components are precision-made, so care must be taken while servicing to avoid damage
- The three 'O' seals located on the outside diameter of the Rada 320 cartridge are static seals. During the operation of the mixing valve these seals are not exposed to the wear and tear associated with 'dynamic' seals. In fact there is no movement within these seals during the operation of the thermostatic unit. The above mentioned inlet 'O' seals should only be replaced when the cartridge is replaced, or when the 'O' seals have been damaged through abnormal treatment. Under normal circumstances the thermostatic cartridge should not need to be removed from the mixing valve body every 12 months, as it is a 'service'free' cartridge.
- Monitoring the performance of the mixing valves as per Australian Standard AS 4032.3 is also recommended. This will make sure that the cartridges (complete with seals) are replaced at suitable periods to facilitate preventative maintenance.

Performance Check

Six Monthly

Exercising the Thermostat: If the valve has not been in regular or recent use the thermostat should be exercised before any other checking. Where user adjustment of the blend temperature is available the exercising of the thermostat can be achieved as described in **COMMISSIONING**. For valves with locked temperature control it is necessary to isolate and restore each supply in turn a few times.

Blend Temperature: check for correct blend setting and/or maximum preset temperature. Reset as necessary

Performance: check blend stability against known datum (e.g. commissioning check) for an induced pressure or flow change. Renew thermostatic cartridge when necessary.

Function: check inlet pipework temperature for correct function of checkvalves, and maintain/renew as necessary. Check and clean strainers as appropriate. Lubricate accessible seals when necessary using silicone-only based lubricant.

In-service Tests

The principal means for determining the continuing satisfactory performance of the mixing valve is the In-service test.

The In-service test procedure is shown in Figure 7. This should be carried out at both 6 to 8 weeks and 12 to 15 weeks after commissioning the valve. The results of these tests are used to determine when, after initial commissioning, the in-service test is next repeated.

Frequency of In-service Tests

The 'Guide to in-service test frequency' is shown in Figure 8. The in-service test results over the first 28 weeks after commissioning determine the ongoing frequency of testing shown in the right hand boxes of the Guide.

Whenever a cartridge is replaced, the in-service test frequency should be reassessed as if it was a new valve.

Note! In-service tests should be carried out with a frequency, which identifies a need for service work before an unsafe water temperature can result. The general principal to be observed after the first 2 or 3 in-service tests is that, intervals of future tests should be set to those which previous tests have shown can be achieved with no more than a small change in mixed water temperature. But in no case longer than 12 months.

Temperature Testing

Check and record warm water temperature regularly to confirm correct operating performance of the valve. In health care applications such as hospitals, aged persons facility, nursing homes etc. such checks must be made at least every month. More regular temperature checks should be made where increased risks are perceived such as where patients are unable to immediately respond to an increase in water temperature by either shutting the water off or removing themselves from the contact with the water. Records of warm water temperature checks should be included in a log book.

Thermostatic Mixing Valve Performance Records (Log Book)

It is recommended that the user maintains a log of the in-service tests described herein, together with a record of any service work carried out and the replacement of cartridges. It is also recommended that any maintenance personnel sign the user log in respect of all thermostatic mixing valves examined on each attendance at the user's premises. **Refer to 'Recommended content of Maintenance Log' on page 29.**

Training

Maintenance personnel should also ensure that the user's staff are aware of the importance of reporting temperature variations and that when detected, these should be recorded in the log. Maintenance Procedures

Maintenance must be carried out in accordance with these instructions, and must be conducted by designated, qualified and competent personnel.

This mixing valve series is designed for minimal maintenance under conditions of normal use.

External surfaces may be wiped clean with a soft cloth, and if necessary, a mild washing-up type detergent or soap solution can be used.

Warning! Many household and industrial cleaning products contain mild abrasives and chemical concentrates, and should not be used on polished, chromed or plastic surfaces.

Should an internal malfunction occur then this will probably require cartridge renewal. The cartridge assembly and check valves contain no user-serviceable parts, and must not be dismantled.

Components are precision-made, so care must be taken while servicing to avoid damage.

When ordering spare parts, please state product type, i.e. Rada 320-t3 cx Aus, and identify part name and number (refer to **PARTS LIST**). A Seal pack is available, containing all the seals that may be necessary for renewal during maintenance or servicing.

Lubricants

Important! All seals are pre-lubricated. If you need to lubricate the seals, use only a small amount of silicone-only based lubricants on this product. Do not use oil-based or other lubricant types as these may cause rapid deterioration of seals.

Maintenance Procedure - Cartridge Assembly

Removal

1. Turn the isolation screw on the isolator valves through 90 ° to isolate the water supplies to the valve (refer to **Figure 4**, Rada 320-t3 cx Aus only). Open an outlet fitting to release pressure and to assist the draining of residual water.
2. Remove the concealing cap and use the 3 mm hexagonal wrench (supplied) to remove the temperature knob concealing cap and screw. Remove the temperature knob, the temperature indicating ring and the hub.
3. Remove the six screws holding the cartridge assembly into the body.
4. Use a suitable tool inserted into the cut-outs to lever the cartridge assembly from the body (refer to **Figure 3**).
5. Remove the cartridge assembly from the body.

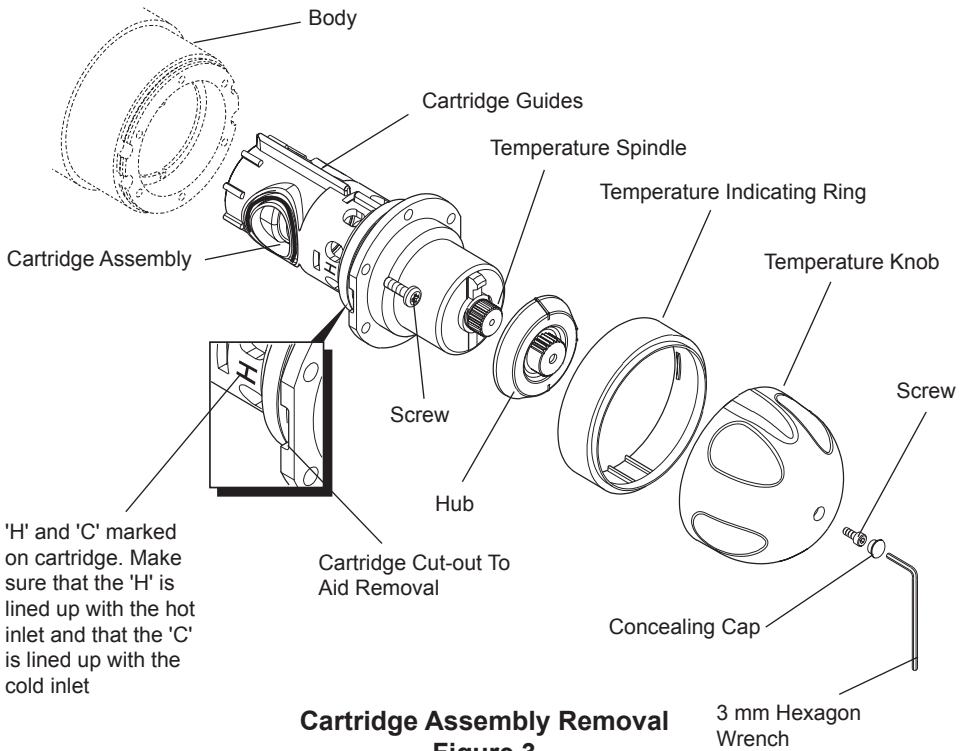

Cleaning/Renewal of Parts

6. The interior surface of the mixing valve body must be clean before re-fitting the cartridge. Rinse the valve interior thoroughly in clean water to remove any debris before refitting the cartridge.

Note! The body interior must be cleaned carefully and not damaged in any way. Do not use any abrasive material.

7. Cartridges may only be cleaned by flushing through under a jet of clean water to remove debris.

Do not descale. Descaling solution MUST not be used on any parts of the 320 valve. Cartridges are not serviceable, and must not be dismantled.

Cartridges cannot be tested individually, service condition should be assessed as part of the performance check; refer **Commissioning Checks**.

8. Examine all accessible seals for signs of deformation or damage, and renew as necessary, taking care not to damage the seal grooves.

Re-assembly

9. Identify which is the hot inlet to the mixing valve body, and align the cartridge assembly accordingly.

Note! There is a 'H' and 'C' marked on the cartridge. Make sure that the 'H' aligns with the hot inlet and that the 'C' aligns with the cold inlet (refer to **Figure 3**).

Align the cartridge guides with the slots in the body and carefully push the cartridge assembly back into the body, checking that the 2 cartridge inlet port seals remain in place.

10. Install the six screws and tighten.
11. Fit the temperature indicating ring.
12. Turn the isolation screw on the isolator valves through 90 ° (Rada 320-t3 cx only) to restore the water supplies to the valve and check for any leaks.
13. Before fitting the hub, the temperature will need re-setting; refer to **COMMISSIONING**.
14. Re-fit the temperature knob.

Maintenance Procedure - Check Valve Cartridges

Hot water entering the cold supply, or vice versa, indicates that immediate attention is necessary. This is carried out by removing and cleaning, or renewing as necessary, the two check valves.

Rada 320-t3 cx Aus

1. Turn the isolation screw on the isolator assemblies through 90 ° (refer to **Figure 4**) to isolate the water supplies to the valve. Open an outlet fitting to release pressure and to assist the draining of residual water.
2. Loosen the isolator grub screws and remove the isolator assemblies from the inlet elbows.

Note! If necessary, loosen the grub screws that hold the valve body onto the backplate. This is so that you can lower the body away from the backplate. This will give you enough clearance to remove the isolator assemblies from the inlet elbows.
3. Remove the inlet elbow grub screws and remove the inlet elbows.
4. Unscrew and remove the check valve housings.

5. Push out the check valves.

The check valve is not a serviceable item, so any apparent wear or damage will require its renewal.

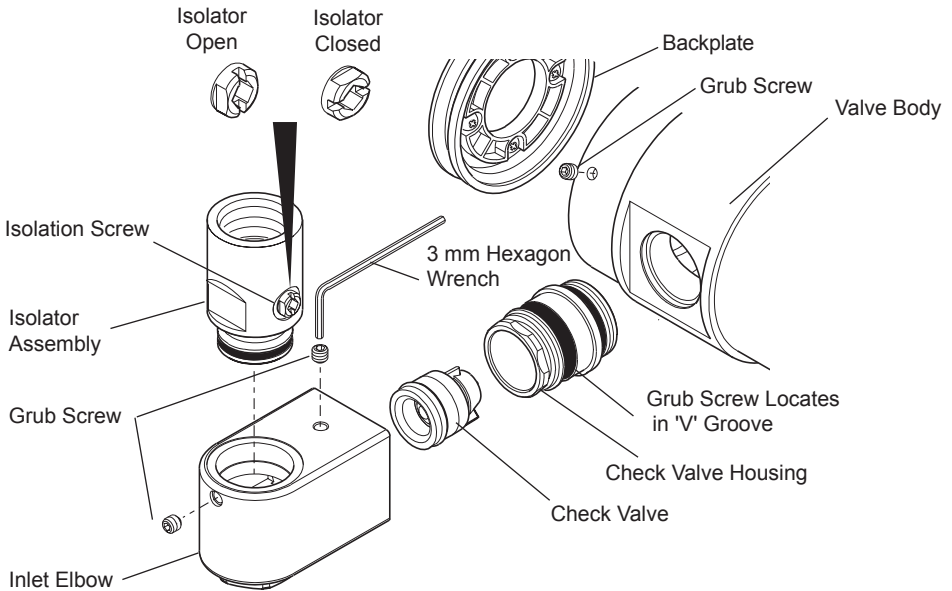

**Check Valves Cartridges
Figure 4**

6. Re-assembly into the valve is a reversal of the above procedures.
7. Turn the isolation screw on the isolator assemblies through 90 ° (refer to **Figure 4**) to restore the water supplies to the valve and check for leaks.

Rada 320-t3 oem Aus

1. Isolate the water supplies to the valve. Open an outlet fitting to release pressure and to assist the draining of residual water.
2. Disconnect the water supplies from the check valve housings.
3. Remove the circlips from the check valve housings.
4. Pull out the check valves.

The check valve is not a serviceable item, so any apparent wear or damage will require its renewal.

5. Re-assembly into the check valve housing is a reversal of the above procedures.
6. Reconnect the water supplies. Restore the water supplies to the valve and check for leaks.

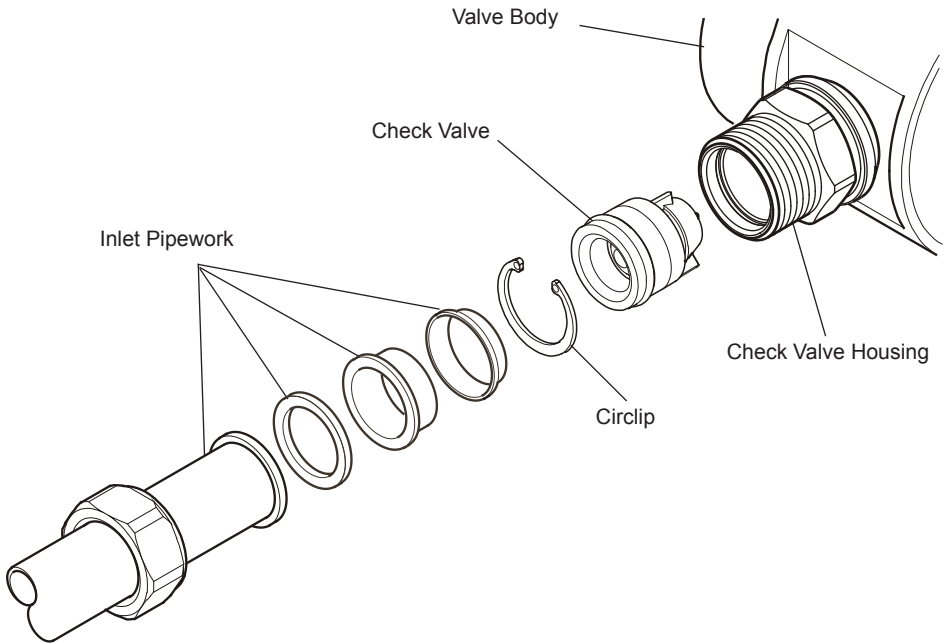

**Check Valves Cartridges
Figure 5**

Maintenance Procedure - Inlet Filters (Rada 320-t3 cx Aus only)

Note! Separate filter provision will be required on the Rada 320-t3 oem Aus.

Blockage of the inlet filters can lead to poor flow performance and reduced temperature control. It is essential that the inlet filters are cleaned or, if necessary, renewed as part of the six-monthly maintenance operations.

A filter pack is available containing two filter screens and all the seals which may be needed during filter inspection (Rada 320-t3 cx Aus only).

1. Turn the isolation screw on the isolator assemblies through 90 ° (refer to **Figure 4**) to isolate the water supplies to the valve. Open an outlet fitting to release pressure and to assist the draining of residual water.
2. Unscrew and remove the blanking cap.
3. The inlet filters are a push-fit into the blanking cap.
4. The strainer screens may be cleaned under a jet of water, or renewed.
5. Re-assembly into the inlet elbows is a reversal of the above procedures.
6. Restore the water supplies and check for leaks.

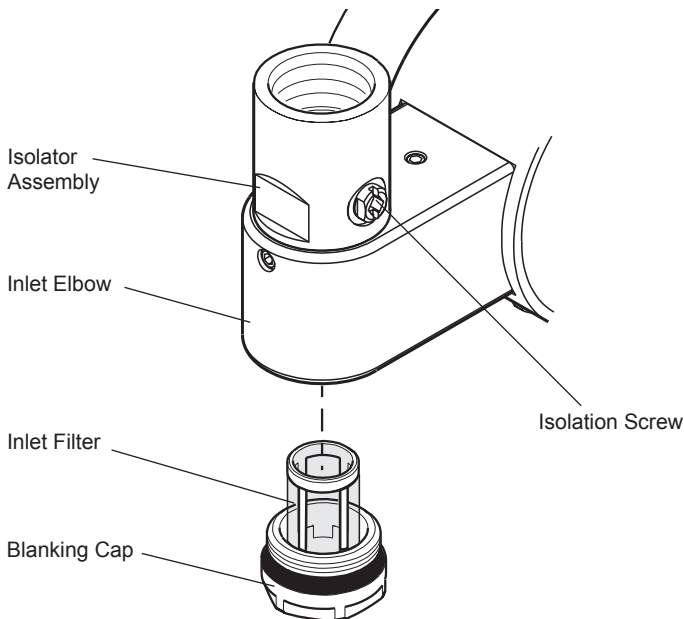

**Inlet Filters
Figure 6**

Recommended Content of Maintenance Log

It is recommended that the Maintenance Log should record the following:

Details of valve, location and use, risk level and instructions

Valve make and model

Valve unique identification number

Valve location

Date installed

Application i.e. type of discharge: bath, shower etc.

Risk assessment report number

Risk level found (e.g. vulnerability of patient)

Frequency of critical component (cartridge) replacement

Frequency of temperature monitoring

Responsibility for temperature monitoring

Location of temperature monitoring records

Source of spares and advice

Issue number of Product Manual (Installation, operating and maintenance instructions).

Details of in-service testing and maintenance

Initial commissioning test data (Supply pressures and temperatures, mixed water temperature, flow rate, result of cold water isolation test, date carried out, signature of maintenance person).

First in-service test due date

First in-service test data (As for initial commissioning)

Details of any remedial work carried out to valve or supply system

Second in-service test due date

Second in-service test data (As for initial commissioning)

Details of any remedial work, including part replacement, carried out to valve or supply system

Next in-service test due date

Next in-service test data (As for initial commissioning)

Details of any remedial work, including part replacement, carried out to valve or supply system.

Note! Local requirements may demand that additional information be recorded.

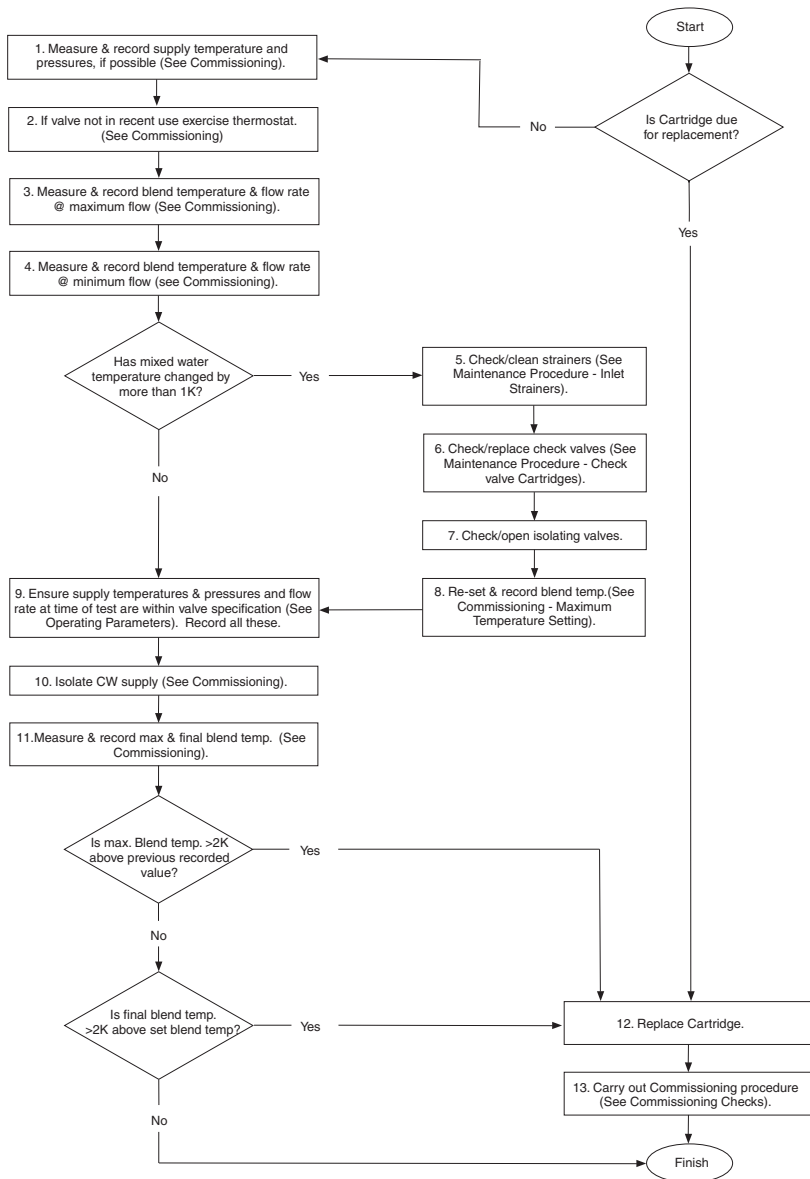

Note! All measurements should be recorded in the Thermostatic Mixing Valve Performance Record (Log Book)

**In-service Test Procedure
Figure 7**

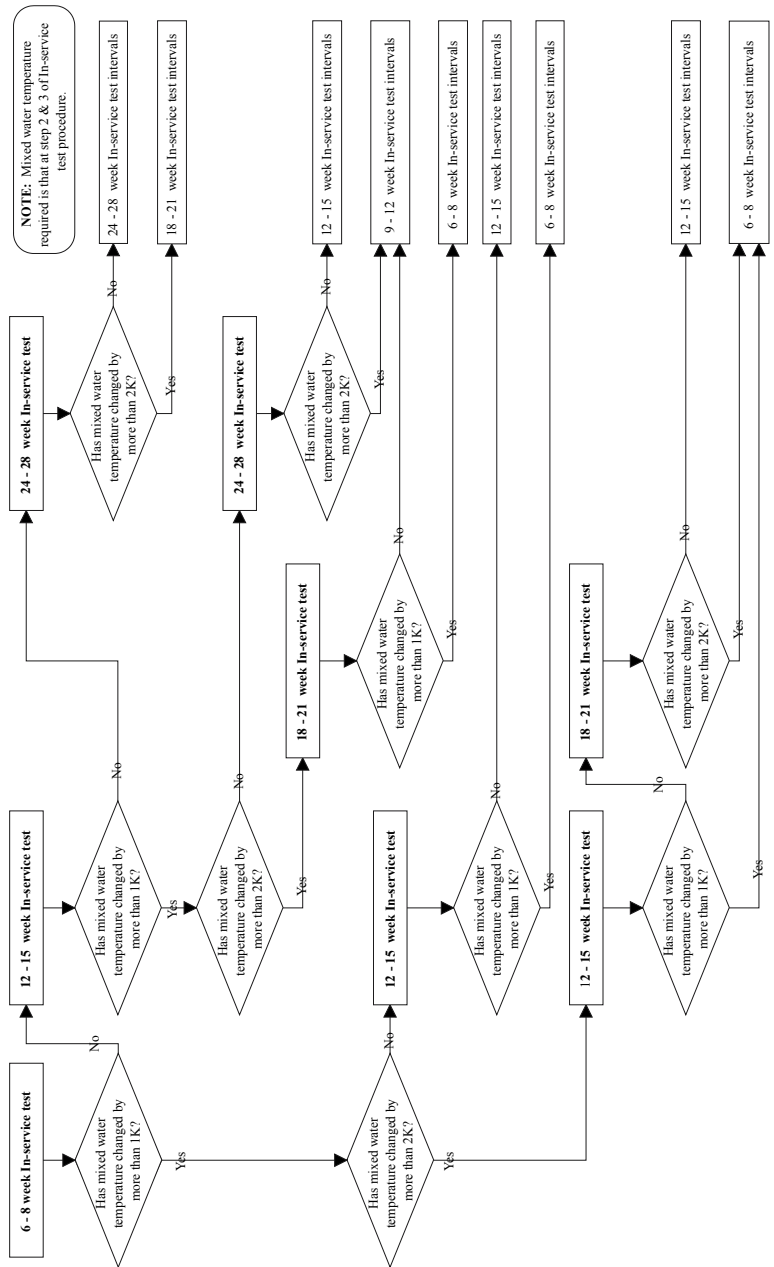

Guide to In-service Test Frequency

Figure 8

SPARE PARTS

320-t3 cx Aus Spare Parts List

414 14	Body
414 43	Temperature Indicating Ring
414 51	Cartridge Assembly
414 80	Hub Pack
414 81	Adaptor, Female
414 84	Seal Pack - components identified 'A'
414 85	Screw Pack - components identified 'B'
414 86	Backplate Kit - components identified 'C'
414 87	Filter Pack
414 88	Inlet Connector Assembly
414 89	Checkvalve Pack - components identified 'D'
414 90	Inlet Elbow Pack - components identified 'E'
414 91	Isolator Assembly
414 92	Knob Pack
414 93	Blanking Cap
575 09	3 mm Hexagonal Wrench

320-t3 cx Aus Spare Parts Diagram

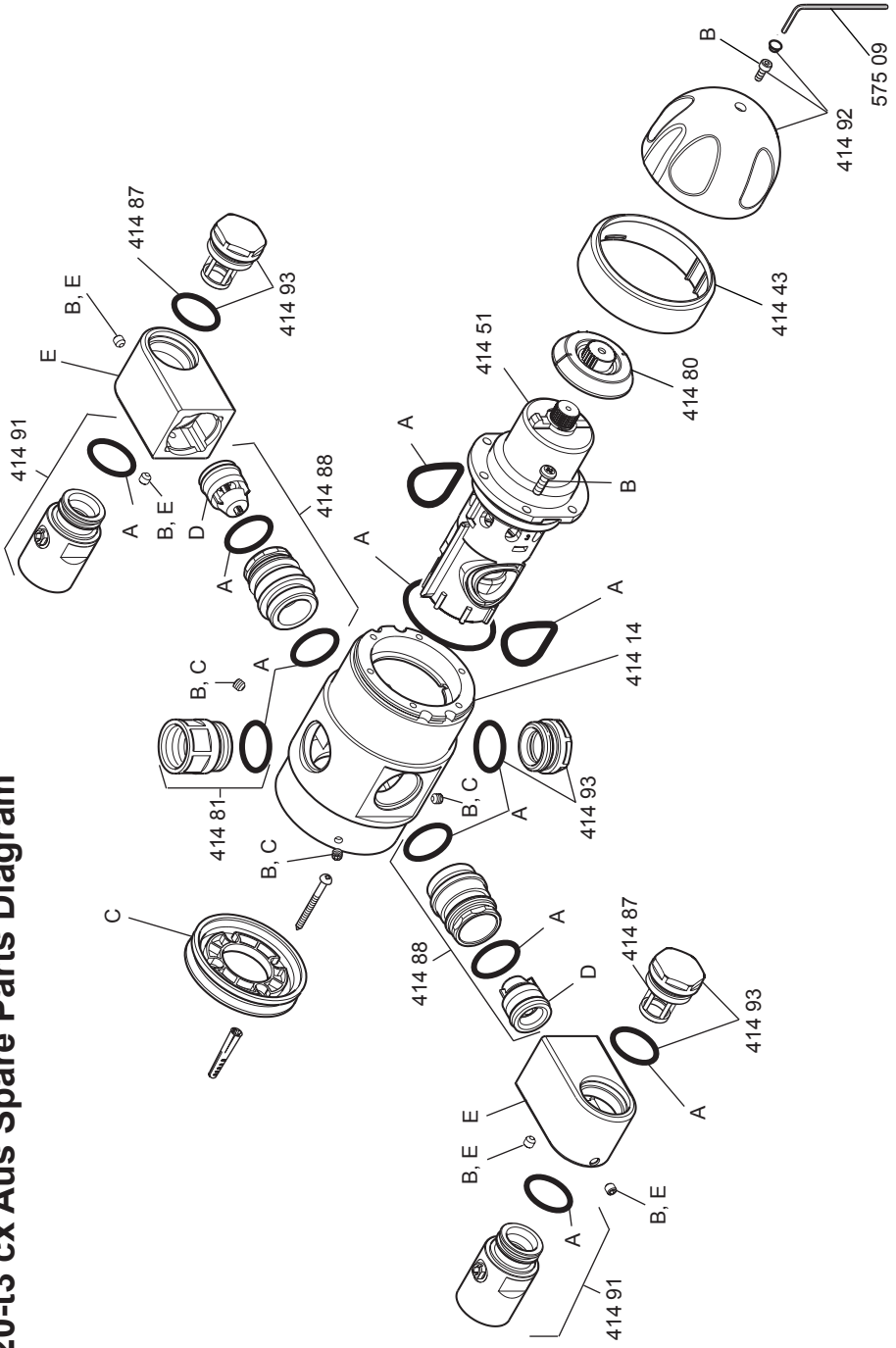

320-t3 oem Aus Spare Parts List

414 14	Body
414 43	Temperature Indicating Ring
414 51	Cartridge Assembly
414 80	Hub Pack
414 82	Male Inlet Adaptor
414 83	Male Outlet Adaptor
414 84	Seal Pack - components identified 'A'
414 85	Screw Pack - components identified 'B'
414 86	Backplate Kit - components identified 'C'
414 89	Checkvalve Pack - components identified 'D'
414 92	Knob Pack
414 93	Blanking Cap
575 09	3 mm Hexagonal Wrench

320-t3 oem Aus Spare Parts Diagram

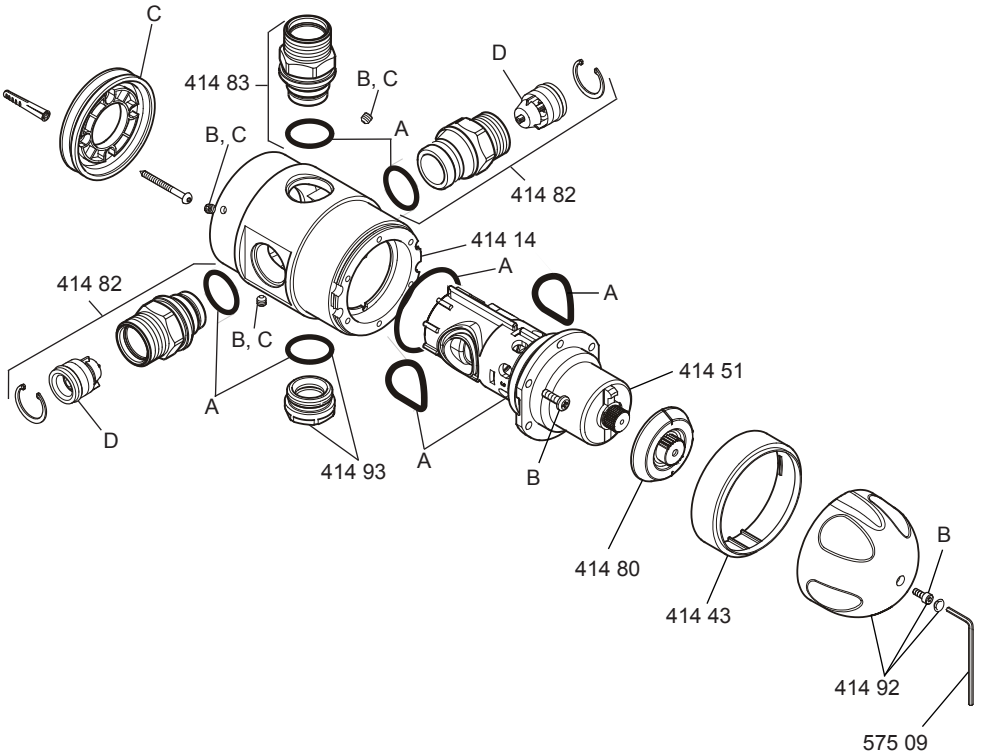

CUSTOMER CARE

Guarantee of Quality

Kohler Mira Limited guarantee this product against any defect in materials or workmanship for a period of two years from the date of purchase.

To be covered by this guarantee, service work must only be undertaken by Kohler Mira Limited or by their approved agents.

Not covered by this guarantee

Damage or defects arising from incorrect installation, improper use or failure to maintain in accordance with the instructions in this product manual, including the build-up of limescale. Defects or damage if the product is taken apart, repaired or modified by a person not authorised by Kohler Mira Limited or by their approved agents.

After Sales Service - how we can help you

We have a network of fully trained staff ready to provide assistance, should you experience any difficulty operating your Rada equipment.

Spare Parts

All functional parts of Rada products are kept for up to ten years from the date of final manufacture. If during that period, our stock of a particular part is exhausted we will, as an alternative, provide an equivalent new product or part at a price equating to the cost of repair to the old, bearing in mind the age of the product.

All spares are guaranteed for 12 months from date of purchase. Spares that have been supplied directly from us can be returned within one month from date of purchase, providing that they are in good order and the packaging is unopened.

Note! Returned spares will be subject to a 15% restocking charge and authorisation must be obtained before return.

Customer Care Policy

If within a short space of time of installation the product does not function correctly, first check with the operation and maintenance advice provided in this Product Manual to see if the difficulty can be overcome. Failing this, contact your installer to make sure that the product has been installed and commissioned in full accord with our detailed installation instructions. If this does not resolve the difficulty, please ring your nearest Rada contact, who will give you every assistance and if appropriate, arrange for your local service engineer or agent to call on a mutually agreeable date.

Contact:

Thornthwaite Technologies Pty Ltd

Howthorn House, 79 Victoria Avenue,

Chatswood, Sydney,

New South Wales, **AUSTRALIA**

Tel: 029 417 4466

Fax: 029 417 5231

www.thornthwaite.com.au

Rada is a registered trade mark of
Kohler Mira Limited.

The company reserves the right to alter
product specifications without notice.

www.radacontrols.com

rada

