

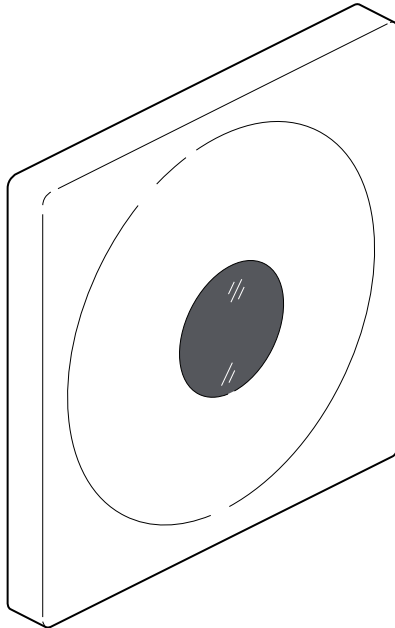

Ligature Resistant Sensor



PRODUCT MANUAL

IMPORTANT

INSTALLER: This product manual is the property of the customer and must be retained with the product for maintenance and operational purposes.

CONTENTS

INTRODUCTION	3
DESCRIPTION	3
PACK CONTENTS	4
SPECIFICATIONS	5
Rada LR Operating System - Schematic	5
DIMENSIONS	6
INSTALLATION	7
Installing the LR sensor.....	7
MAINTENANCE	9
Cleaning	9
FAULT DIAGNOSIS	9
SPARES	10
NOTES	11
CUSTOMER CARE	12

INTRODUCTION

The Rada Ligature Resistant Sensor (LR Sensor) is a vandal resistant sensor designed for use in secure units. Depending on your required installation, the three basic elements can be varied in quantity and type to suit the installation.

The system elements comprise of:

The Rada LR Sensor

This Product Manual covers the installation of this product

The Control box and the Solenoid Valve

Refer to the Rada Pulse Electronic Washroom Product Manual

Reference number: 1057328-W2-A

DESCRIPTION

The user activates the LR Sensor, the flow of water to the washbasin or shower runs for a preset period, after which the water is automatically shut off. If the user wishes to continue they simply reactivate the sensor. Time setting functions can be easily programmed into the **Rada Pulse Control Box** using the **Rada Pulse Hand Held Programmer**.

All electrical connections are totally sealed and the system operate at a very safe low voltage.

The LR Sensor has been designed to be recessed or built within the wall surface, to allow for extra security. Recommended guidelines are given in the 'Installation' section.

If you experience any difficulty with the installation or operation of your new LR Sensor, please read both Product Manuals carefully before contacting Kohler Mira Limited. Our telephone and fax numbers can be found on the back cover of this guide.

PACK CONTENTS

Tick the appropriate boxes to familiarize yourself with the part names and to confirm that the parts are included.

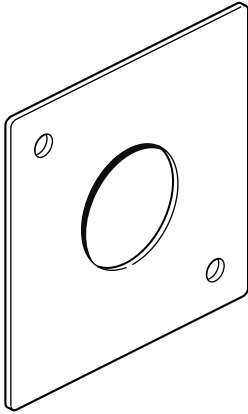

1 x LR Sensor Backplate

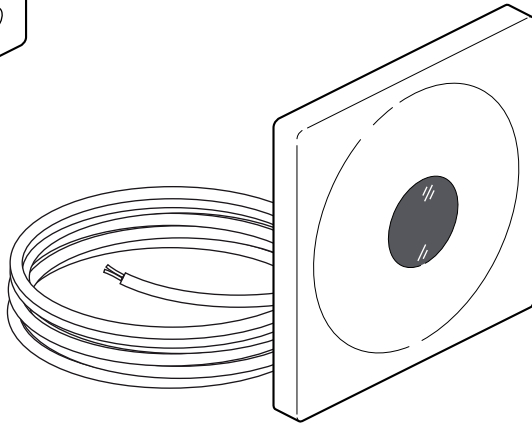

1 x LR Sensor
complete with 3.0 metre 2 core cable

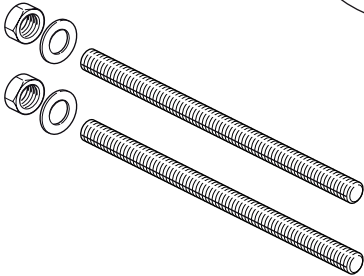

2 x M6 x 175 mm Fixing Studs
with Fittings



1 x Plug-in Connector

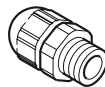

1 x Cable Gland



2 x Watertight 3m Connectors

Documentation

1 x Product Manual

SPECIFICATIONS

Material	Brass
Finish	Chrome plated
Cable	3 m of 2 core sheathed cable with connections sealed into the sensor
Operating voltage	12 V AC via the 2 core cable
Temperature range	4 to 70 °C
Protection	IP65
Activation distance	0 to 50 mm depending on the reflectivity of the object
Attachment	2 x M6 x 175 mm fixing studs (rear fixing)

Rada LR Operating System - Schematic

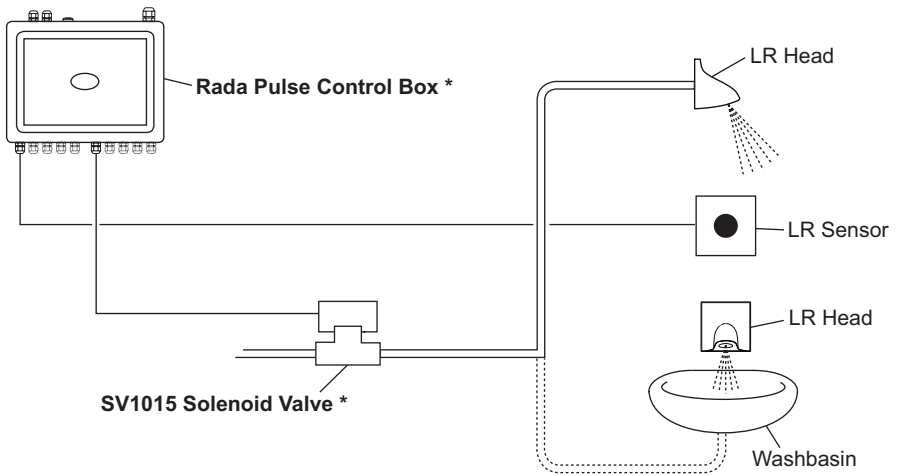

* Refer to the Rada Pulse Electronic Washroom Product Manual for additional information on these products.

DIMENSIONS

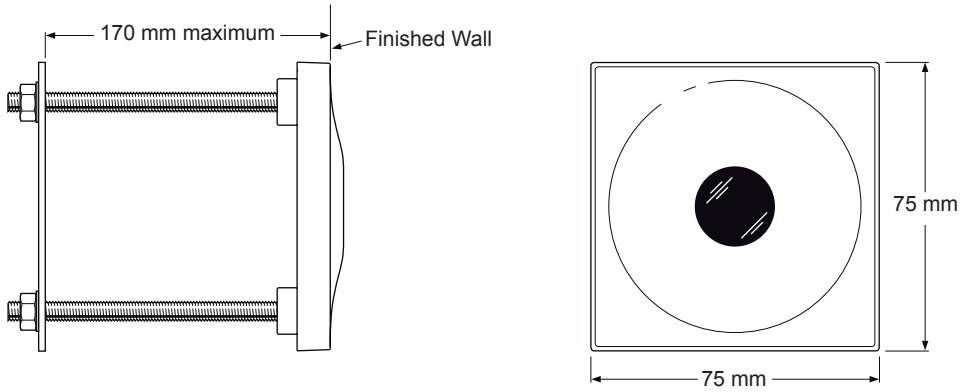

Note! The M6 fixing studs supplied allow the LR sensor to be attached through a wall to a maximum thickness of 165 mm. If longer M6 fixing studs are required, these will have to be purchased through your local supplier.

INSTALLATION

General

Installation must be carried out in accordance with these instructions, and must be conducted by designated, qualified and competent personnel.

Important! The instructions contained in this product manual is for the installation of the LR Sensor only.

If the LR Sensor is to be used in a controlled washroom environment, for example using a Rada Pulse System, please read both product manuals before installing your LR Sensor.

Installing the LR sensor

The LR Sensor has been designed to be recessed or built within the wall. To allow for extra security the LR Sensor must be installed flush with the finished wall.

Note! The LR Sensor is the same size as a single electrical mounting box and the recommended method of recessing the LR Sensor is to use an Electrical Box Sinker Tool. An alternative method would be stitch drilling then to use a club hammer and chisel.

1. Decide on a suitable location for the LR Sensor.
2. Position the LR Sensor backplate onto the level finished wall.

Note! Use a spirit level to make sure that the LR Sensor backplate is horizontal.

Make sure the M6 fixing studs holes are in the correct position for the LR Sensor.

3. Mark the centre positions for the M6 fixing studs and the sensor cable.
4. Drill pilot holes for the centres of the three holes.
5. Use the electrical box sinker tool to recess the wall to a depth of 10,5 mm (± 1 mm).
6. To allow for the lugs on the rear of the LR Sensor, the fixing stud holes will require a further recess of $\text{Ø}20$ mm x 10 mm (± 1 mm).
7. Recess a channel for the sensor cable.

Note! It's recommended to use a $\text{Ø}10$ mm and then a $\text{Ø}20$ mm drill bit.

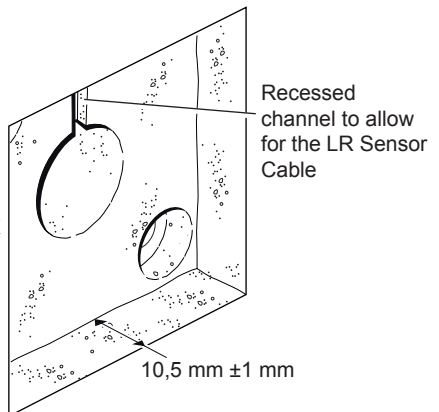
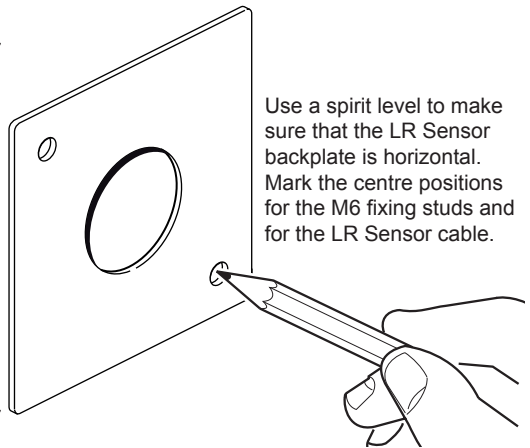

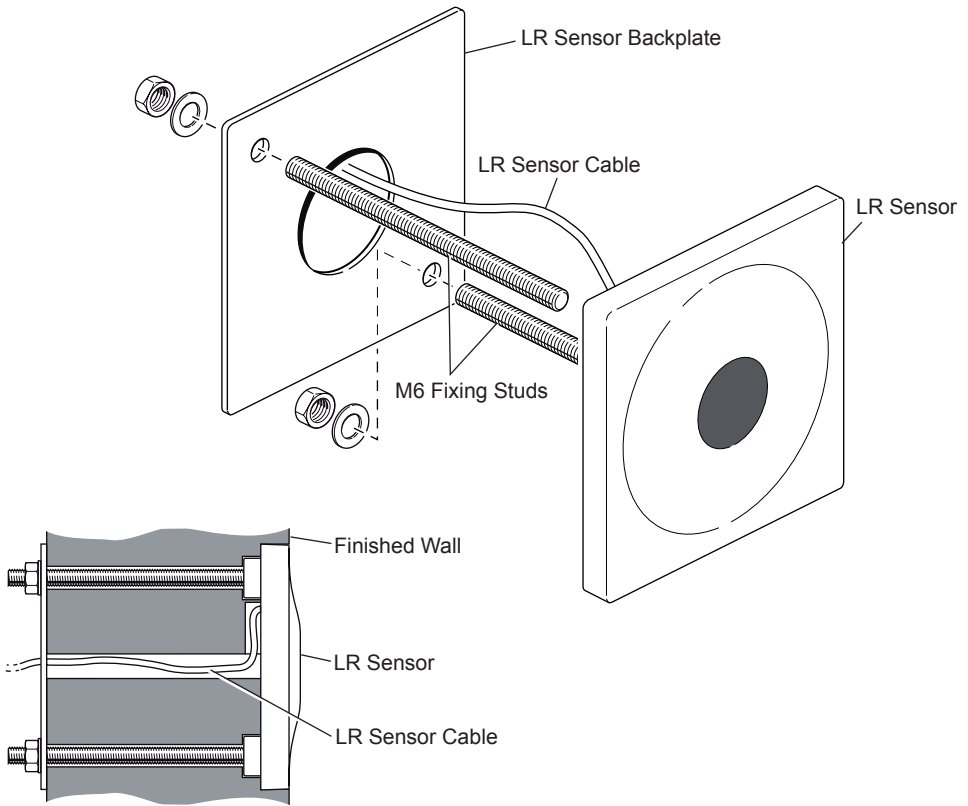

8. Drill the centre hole ($\text{\O}10\text{ mm}$) to allow for the LR Sensor cable.
 9. Check that the LR Sensor can be installed flush with the finished wall.
 10. Attach the M6 fixing studs to the LR Sensor and put it into position.

Note! Make sure that the LR Sensor cable does not become caught.
 11. Place the LR Sensor backplate/washers over the M6 fixing studs and secure with the nuts.
 12. Grout around the LR Sensor with hard setting compound.
- The installation of the Rada LR Sensor is complete, refer to the Rada Pulse Electronic Washroom product manual to commission your system.

MAINTENANCE

Cleaning

Many cleaners contain abrasive and chemical substances and should not be used for cleaning plated or plastic fittings. These finishes should be cleaned with a mild washing up detergent or soap solution, and then wiped dry using a soft cloth.

FAULT DIAGNOSIS

Please refer to the Rada Pulse Electronic Washroom Product Manual for any fault finding diagnosis of your system.

SPARES

1640.033 LR sensor backplate assembly
(LR sensor backplate, 2 x M6 x 175 mm fixing studs with fittings)

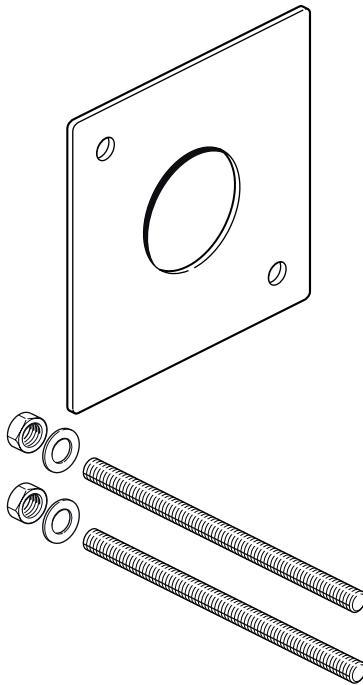

NOTES

CUSTOMER CARE

Guarantee

Kohler Mira Ltd. guarantee this product against any defects in materials or workmanship for a period of one year from the date of purchase.

To be covered by this guarantee, service work must only be undertaken by Kohler Mira Ltd. or approved agents.

Not covered by this guarantee

Defects or damage arising from incorrect installation, improper use or failure to maintain in accordance with the instructions in the product manual, including the build-up of limescale. Defects or damage if the product is taken apart, repaired or modified by a person not authorised by Kohler Mira Ltd. or approved agents.

After Sales Service - how we can help you

We have a network of fully trained staff ready to provide assistance, should you experience any difficulty operating your Rada equipment.

Spare Parts

All functional parts of Rada products are kept for up to ten years from the date of final manufacture. If during that period, our stock of a particular part is exhausted we will, as an alternative, provide an equivalent new product or part at a price equating to the cost of repair to the old, bearing in mind the age of the product.

All spares are guaranteed for 12 months from the date of purchase. Spares that have been supplied directly from us can be returned within one month from the date of purchase providing that they are in good order and the packaging unopened.

Note! Returned spares will be subject to a 15% restocking charge and authorisation must be obtained before return.

Customer Care Policy

If within a short space of time of installation the product does not function correctly, first check with the operation and maintenance advice provided in this Manual to see if the difficulty can be overcome. Failing this, contact your installer to make sure that the product has been installed and commissioned in full accord with our detailed installation instructions. If this does not resolve the difficulty, please ring your nearest Rada contact who will give every assistance and, if appropriate, arrange for the local Service Engineer or Agent to call on a mutually agreeable date.

Contact:

Rada Controls

Cromwell Road,
Cheltenham,
England, GL52 5EP, UK
Telephone: +44 (0)870 600 0221
Fax: +44 (0)1242 221925

SPECIFICATION ENQUIRIES

Telephone: +44 (0)1242 282527
Fax: +44 (0)1242 282404
E-Mail: rada_technical@mirashowers.com

Rada is a registered trade mark of
Kohler Mira Limited.
The company reserves the right to alter
product specifications without notice.
www.radacontrols.com

The Rada logo consists of the word "rada" in a bold, lowercase, italicized sans-serif font. Below the text are three horizontal lines of varying lengths, with the longest line centered under the letters.

FM 14648