

Assembly A50154 & A50155

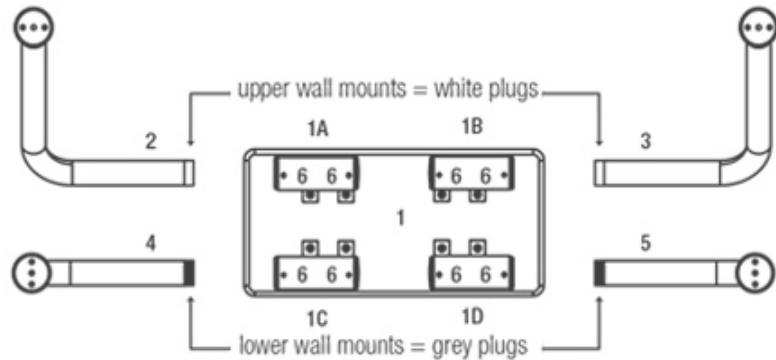

Wall Fixing

Top Fixing

Mark 937 mm from floor and 70 mm either side of cistern.

Bottom Fixing

Mark wall 642 mm from floor and 70 mm either side of cistern.

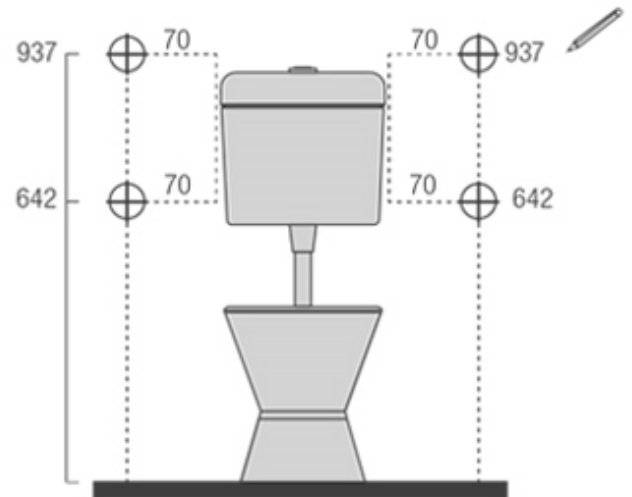

NOTE: Loosen grub screws (6) before commencing installation

1. Sub-assemble **backrest (1)**
2. Insert **upper wall wall mounts with white plugs (2 & 3)** into support tubes (1A & 1B)
3. Adjust the distance between wall mount flanges to 76 mm less than the measurement between vertical wall marks and gently tighten grub screws
4. Place top centre of the **upper wall mount flanges (2 & 3)** on the top fixing mark and mark preferred fixing holes
5. Insert **lower wall mounts with grey plugs (4 & 5)** into support tubes (1C & 1D) and repeat from step 4 with lower wall mounts
7. Tighten all wall fixings
8. Centre **backrest (1)** to toilet and tighten **grub screws (6)**

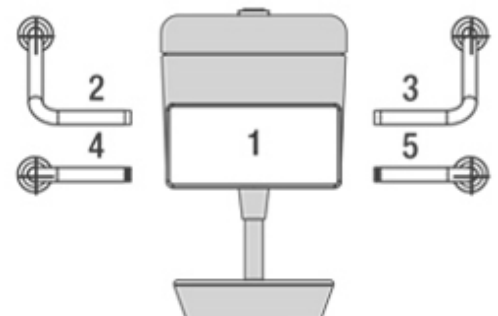

1

Position the flange protector guide lugs on the centre line, horizontal or vertical as appropriate to the wall construction. Centre protection guide on the other wall mark then mark at fixing lugs.

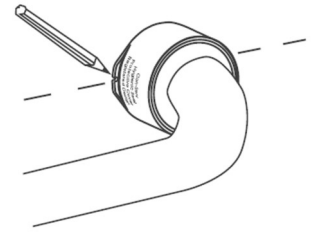

2

Remove flange protector from grab rail flange, align guide lug marks from step 1 and mark wall through base holes to pinpoint screw holes.

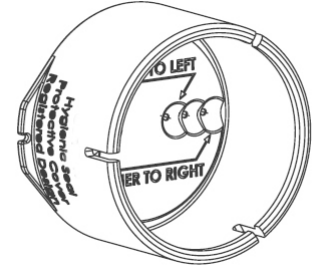

3

Fit dress ring if applicable. Drill spot marks with 7 mmbit,. Drill Spot marks with 7 mm bit. Screw wall mount plate to wall. ENSURE SCREWS ENGAGE WALL STUD OR OTHER SOLID

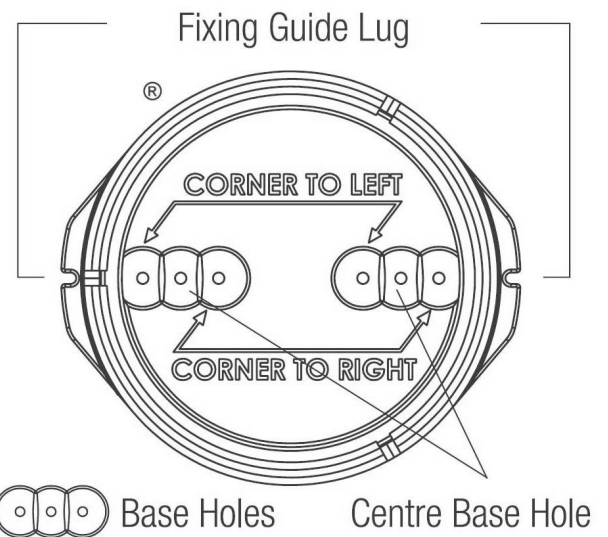
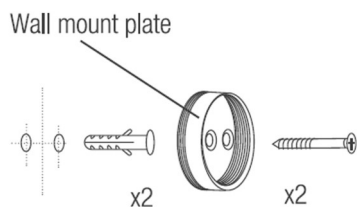

4

Fit grab rail into wall mount plate and tighten lock nut firmly.



5

Screw flange cover to wall mount plate the thermo-plastic elastomer fitted seal.

