

rada

215 SERIES

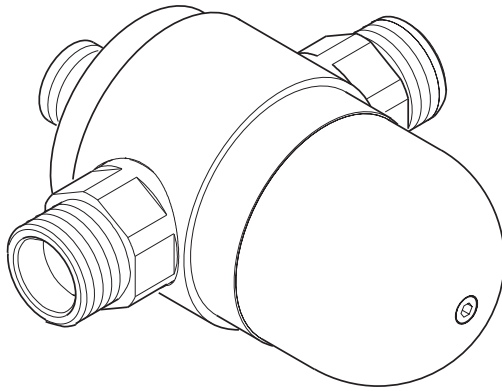

NSW Health Approved

PRODUCT MANUAL

IMPORTANT

INSTALLER: This Manual is the property of the customer and must be retained with the product for maintenance and operational purposes.

CONTENTS

Safety : Warnings	3
Advice.....	3
Introduction	4
Healthcare Installations	4
Patents	4
Specifications	5
Dimensions.....	8
Installation	9
General.....	9
Water Supply Authorities Conditions	9
Outlet Position/Reversed Inlets	11
Rada 215 dk.....	13
Pipework and Flushing.....	13
Commissioning	14
Operation	16
Fault Diagnosis.....	17
Maintenance.....	18
General.....	18
Planned Maintenance Programmes (preventative/precautionary maintenance).....	18
Frequency of In-Service tests.....	20
In-Service Test Procedure	21
Thermostatic Cartridge.....	24
Checkvalve Cartridges	26
Inlet Strainers	27
Elbow/Body Seals	27
Spare Parts	28
Rada 215 series: Strainer and Service Packs component matrix	30
Customer Care.....	Back Page

SAFETY : WARNINGS

The function of this thermostatic mixing valve is to deliver water consistently at a safe temperature. This requires that:

1. It is installed, commissioned, operated and maintained in accordance with the recommendations given in this manual.
2. Periodic attention is given, as necessary, to maintain the product in good functional order. Recommended guidelines are given in section: **'Maintenance'**.
3. Continued use of this product in conditions outside the specification limits given in this manual can present potential risk to users.

ADVICE

1. The use of the word **'failsafe'** to describe the function of a thermostatic mixing valve is both incorrect and misleading. In keeping with every other mechanism it cannot be considered as being functionally infallible.
2. Malfunction of thermostatic mixing valves is almost always progressive in nature and will be detected by the use of proper temperature checking and maintenance routines.
3. Certain types of system can result in the thermostatic mixing valve having excessive 'dead-legs' of pipework. Others allow an auxiliary cold water supply to be added to the mixed water from the mixing valve. Such systems can disguise the onset of thermostatic mixing valve malfunction.
4. Ultimately, the user or attendant must exercise due diligence to make sure that the delivery of warm water is at a stable, safe temperature. This is particularly important in such healthcare procedures as supervised bathing of patients unable to respond immediately to unsafe temperatures.
5. Care is required when making any adjustments to flow or temperature. Make sure that the temperature is suitable and has stabilised.
6. To ensure continued safe operation of this product, all **'Critical Components'** should be changed every **5 years**.
7. The designed service life of all critical components used in this product is 5 years providing it is operated within the recommended operating conditions and parameters. However, when supply conditions and/or usage patterns do not conform to the recommended operating parameters and/or conditions the critical components may need to be replaced frequently in line with the appropriate risk assessments.
8. Continued use of this product in conditions outside the specification limits given in this manual can present potential risk to users.

9. Important! In healthcare applications such as hospitals, aged person facilities, residential care homes etc., and in any other applications where the user is similarly at risk, irrespective of supply and usage conditions or the evidence of in-service tests, the Critical Components **MUST** be replaced at intervals of no more than 5 years.

10. Critical Components are considered as:

408.99	Thermostatic Cartridge Assembly, 215 Series
408.68	Checkvalve Cartridge; 215 dk/oemk
408.75	Checkvalve Cartridge; 215 bk
408.91	Strainer Pack; 215 series
147.67	Checkvalve Insert Pack 215 dk/bk

If you experience any difficulty with the installation or operation of your new Mixing Valve, please refer to “**Fault Diagnosis**”, before contacting Thornthwaite Technologies Pty Ltd. Our contact details can be found on the back cover of this guide.

INTRODUCTION

Rada thermostatic mixing valves are specified to meet the highest standards of safety, comfort and economy as demanded by todays users. All Rada products are designed, manufactured and supported in accordance with accredited BS EN ISO 9001:2000 Quality Systems.

A range of DN15/DN20 thermostatic mixing valves to suit a wide diversity of applications and installation formats.

Incorporates a unique sealed-for-life thermostatic cartridge utilising proven durability high-technology materials for extended service-free reliability. This cartridge employs a state of the art thermostatic temperature sensor to provide water at safe, accurate temperatures for ablutionary or process requirements.

The mixing valve inlets incorporate strainers and checkvalves, housed within readily accessible cartridges for easy maintenance.

The products are supplied with the temperature control locked. Once the outlet temperature has been set, it cannot be adjusted without removing the locking cap and temperature hub.

An optional adjustable temperature knob is available as an accessory (408.89) which will allow user adjustable temperature control.

Healthcare Installations

The relevant authorities approve the following Rada thermostatic mixing valves for use in healthcare buildings:

Rada 215 dk

Rada 215 bk

Rada 215 oemk

Patents

Patents:	GB: 2 291 693, 2 340 210, 2 421 297, 2 392 225 USA: 7 240 850 Euro: 1 672 257 DE, FR, GB, IT, NL, SE
Patent Applications:	Euro: 03254070.0 USA: 2006-0124758-A1, 2007-0221740-A1

SPECIFICATIONS

Normal Operating Conditions are considered as:

- Inlet dynamic pressures nominally balanced to within 10% of each other during flow.
- A differential of approximately 30°-50°C between the hot and cold inlet temperatures, and with differentials of 12-35°C between the blend setting and either supply.
- Installation and usage environment not subject to extremes of temperature, unauthorised tampering or wilful abuse.

Other Applications

For information on other specific applications or suitability, refer to Thornthwaite Technologies Pty Ltd or Kohler Mira Ltd.

Disinfection

In applications where system chemical disinfection is practised, chlorine can be used (calculated chlorine concentration of 50 mg/l (ppm) maximum in water, per one hour dwell time, at service interval frequency). Such procedures must be conducted strictly in accordance with the information supplied with the disinfectant and with all relevant Guidelines/Approved Codes of Practice. If in any doubt as to the suitability of chemical solutions, refer to Thornthwaite Technologies Pty Ltd or Kohler Mira Ltd. The system must be flushed with fresh water to remove any high levels of chlorinated water in the system.

Continuous chlorine dosing is not recommended.

Operating Parameters - Pressures/Flow Rates

For optimum performance, dynamic supply pressures should be nominally equal.

Recommended Minimum Flow Rate: 2.5 l/min at mid-blend with equal dynamic supply pressures.

Recommended Maximum Flow Rate: 50 l/min at mid-blend (which equates to maximum pressure loss of 425 kPa (4.25 bar)).

Maximum Pressure Loss Ratio*: should not exceed 10:1, in favour of either supply, during flow.

Recommended Minimum Dynamic Supply Pressure: 15 kPa (0.15 bar).

Recommended Maximum Dynamic Supply Pressure†: 500 kPa (5 bar).

Maximum Static Supply Pressure†: 1000 kPa (10 bar).

Recommended maximum flow velocity in pipelines is 2 metres/second.

† If either of these values is likely to be exceeded then a drop tight pressure reducing valve must be fitted.

* Pressure Loss Ratio is determined by subtracting the resistance to flow of the outlet pipework and outlet fittings (generally known as "back pressure", and measured at the outlet of the Mixing Valve) from the dynamic pressures of the hot and cold water at each inlet of the Mixing Valve. This is at its extreme when the Mixing Valve is being used at its lowest flow-rate and when the maximum inequality occurs in the pressure of the hot and cold water supplies.

Hydraulic Restriction: Flow Rate/Pressure Loss Graph

(mixing valve only, equal dynamic supply pressures and mid-blend temperature, rising or falling pressure loss)

215 cartridge 90° elbows & no filters

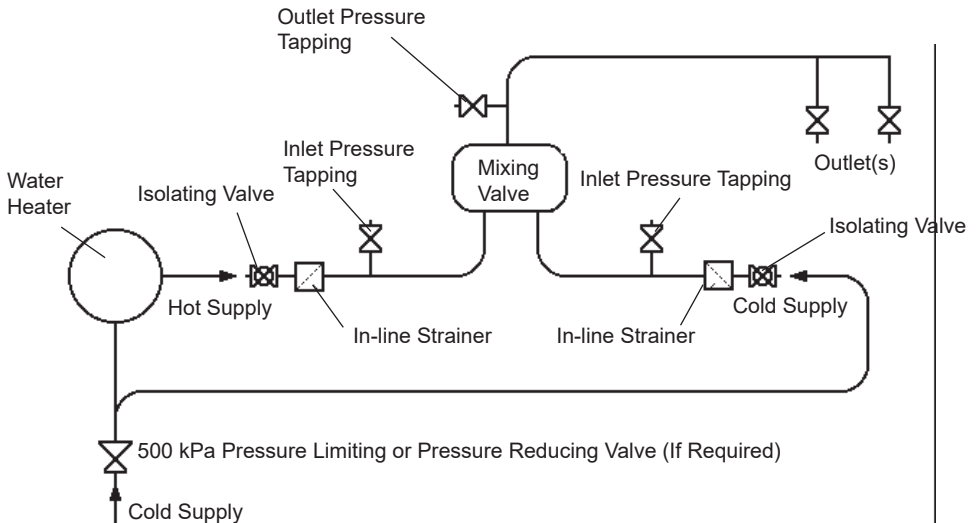
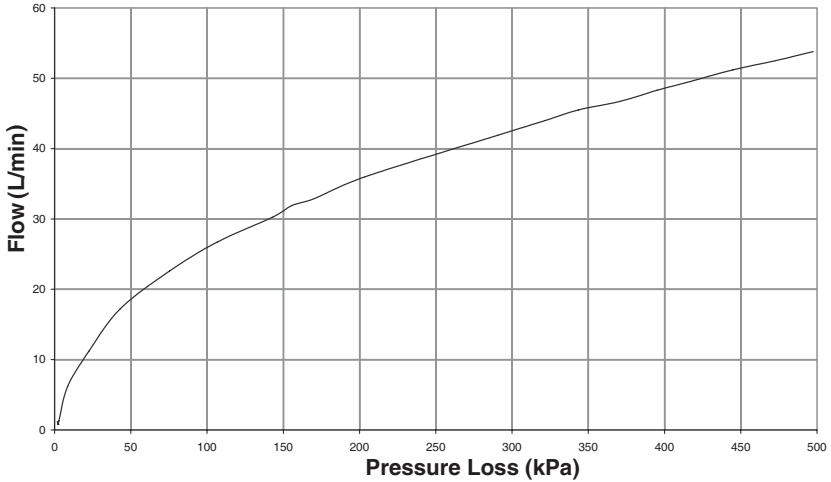

Installation schematic showing additional installation features (if required)

Refer also to page 108, Fig 4, "HOSPLAN Code of Practice for Warm Water Ablution Systems Incorporating Thermostatic Mixing Valves", which is published by the NSW Health.

Temperatures

- Factory Pre-set (Blend): **41°C** (under ideal installation conditions)
- Blend Temperature Range: **full cold to approximately 60°C**, depending on hot water supply temperature.
- Optimum Thermostatic Control Range: **35°C to 50°C** (achieved with supplies of 15°C cold, 65°C hot and nominally equal pressures).
- Recommended Hot Supply: **60°C to 65°C** Note! For safety reasons it is recommended that the maximum hot water temperature is limited to 65°C.
- Maximum Hot Water Supply: **70°C***

***Caution!** During thermal disinfection the mixing valve can operate up to 85°C for short periods. Ensure safety precautions are followed during discharge. Chemical disinfection agents e.g. chlorine/chloramines combined with higher temperatures will affect the life of the product adversely and could detrimentally affect the thermostatic performance.

- Cold Water: **1°C up to 25°C**
- Minimum Recommended Differential between Hot Supply and Outlet Temperature: **12°C**.

Thermostatic Shut-down

- For safety and comfort the thermostat will shut off the mixing valve **within 2 Seconds** if either supply fails (achieved only if the blend temperature has a minimum differential of 12°C from either supply temperature).

Both the mixing valve and the water supplies must be protected from freezing. This may require a combination of adequate pipe insulation and provision of background heating. If there is any doubt that freezing will not be prevented, then the water supplies and the mixing valve should be drained.

Flow Control

Rada 215 series mixing valves do not have integral flow control; appropriate provision must be made for this in the outlet pipework.

This can be in the form of basin/bath tap, stopcock, mechanical timed-flow controller or solenoid. The device chosen must be non-concussive in operation.

Outlet: top (can be altered to bottom as required, refer to section: '**Installation**').

All models can operate in any plane, and may be inverted if necessary for pipework layout convenience, provided hot and cold pipework is connected to the appropriate inlets (**hot = red, cold = blue**).

Note! Should the supplies be reversed then the mixing valve will not be able to control temperature. This can be corrected by reversing the position of the thermostatic cartridge within the mixing valve body, refer to section: '**Installation**'.

Approvals

Product 215 DK complies with the requirements of Lead Free Standards as defined in the Australian National Construction Code Volume 3 and is suitable for use as part of a Lead Free installation.

Dimensions

Rada 215 bk

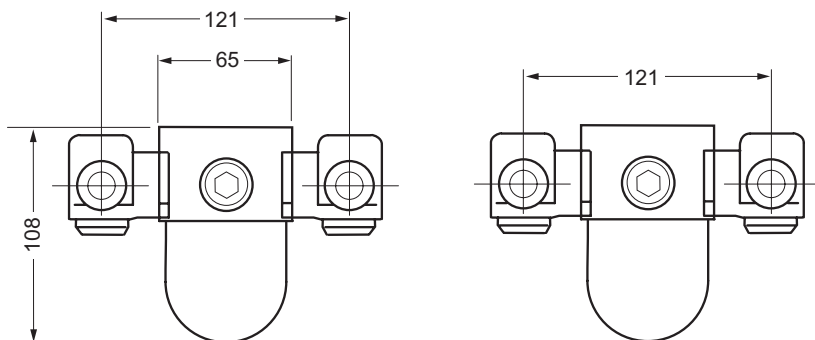

Rada 215 dk

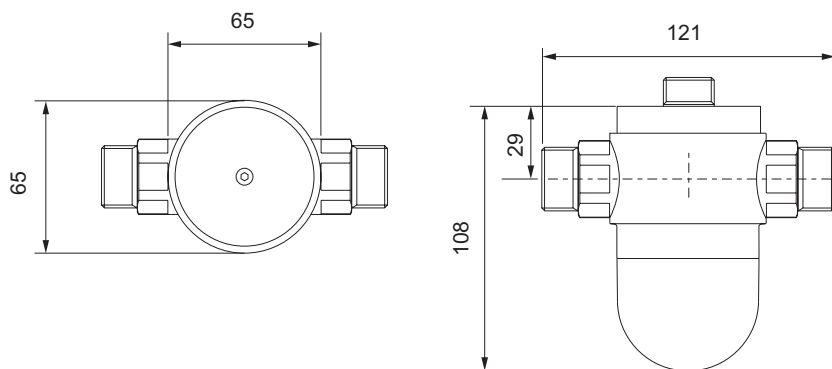

All dimensions in mm

INSTALLATION

NSW Health Requirements

Refer to NSW Health Policy Directive PD2005_344 (a copy of which can be obtained from www.health.nsw.gov.au).

Key documents detail the correct system design, installation, commissioning, operation, maintenance, service and site management procedures, which must be followed regarding TMVs.

These documents include:

- The current TMV supplier's instructions
- The Code of Practice for Thermostatic Mixing Valves, 1990, (HOSPLAN)
- Relevant Australian Standards:
AS 4032 – Thermostatic Mixing Valves – materials, design and performance.

The hot water system shall comply with the:

- Public Health Act 2010
- Public Health Regulation 2012

General

Installations must be carried out in accordance with the requirements of the Plumbing Code of Australia.

Refer to the following Australian Standards:

- AS/NZS 3500.4 Plumbing & drainage heated water services.
- AS 4032.1 - Material, design & performance requirements.
- AS 4032.3 - Requirements for field testing, maintenance or replacement.

1. Before commencing, make sure that the installation conditions comply with the information given in section: '**Specifications**'.
2. Care must be taken during installation to prevent any risk of injury or damage.
3. Installations must comply with Plumbing Code of Australia.
4. The mixing valve should be positioned for easy access during use and maintenance. All routine maintenance procedures can be conducted with the mixing valve body in place (except for strainer and checkvalve access on 215dk). For all models, allow a minimum 80 mm clearance in front of the temperature control to enable removal of the thermostatic cartridge during maintenance.
5. The use of supply-line or zone strainers will reduce the need to remove debris at each mixing valve point. The recommended maximum mesh aperture dimension for such strainers is 0.5 m, unless the integral strainer screens have been removed when the maximum mesh aperture should be 0.25 mm (refer to Installation Procedure for the 215 dk).

- 6.** Pipework must be rigidly supported.
- 7.** Inlet and outlet pressure tappings which allow measurement of the inlet and outlet pressures at the mixing valve under running conditions are required in healthcare applications.
- 8.** Pipework dead-legs should be kept to a minimum.
- 9.** Supply pipework layout should be arranged to minimise the effect of other outlet usage upon the dynamic pressures at the mixing valve inlets.
- 10.** Inlet and outlet threaded joint connections should be made with PTFE tape or liquid sealant. Do not use oil-based, non-setting jointing compounds.
- 11.** To eliminate pipe debris it is essential that supply pipes are thoroughly flushed before connection to the mixing valve.

Outlet Position/Reversed Inlets

Rada 215 dk models are readily adaptable for rising or falling pipework; flat-faced union connectors will allow the valve body to accept a variety of pipework configurations, and to be reversed or inverted as appropriate.

All Rada 215 series mixing valves, except 215 dk, are supplied with inlet connections configured **hot - left, cold - right, and top outlet** as standard. It is essential that inlet supplies correspond with the red and blue markings on the thermostatic cartridge. Should the existing hot and cold pipework make this configuration inconvenient, or a bottom outlet position be required, the valve inlets or outlet can be reversed, as detailed below. If both the outlet and inlet positions require reversing, it is easier to simply rotate the complete mixing valve by 1/2 turn, and then reposition the locking cap.

Outlet Reversal should be done **prior** to installation of the mixing valve body. Rotate the body 1/2 turn so that the outlet is in the opposite direction, then follow the procedure for reversing the cartridge .

Reversed connections can be altered before or after the mixing valve has been installed. Follow procedure for reversing the cartridge.

Reversing the Cartridge

1. If the thermostatic mixer has already been installed, isolate the water supplies, and open an outlet fitting to release pressure and to drain any residual water.
2. Unscrew the locking cap screw using a 3 mm hexagonal key (supplied) and remove the locking cap.

Note! Do not remove the temperature hub.

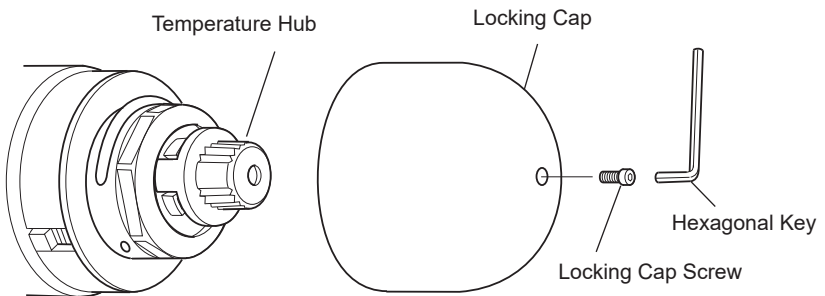

3. With the removal clip still in place, unscrew the head nut fully using a 35 mm A/F wrench and pull the thermostatic cartridge free from the mixing valve body.

Caution! Some residual water may be released.

4. Rotate the thermostatic cartridge 1/2 turn, which reverses the position of the cartridge hot and cold inlets.
5. Make sure that the cartridge inlet seals are greased and carefully push the thermostatic cartridge back into the mixing valve body, checking that the 2 cartridge inlet seals remain in place, and locate the cartridge lugs into the body slots.

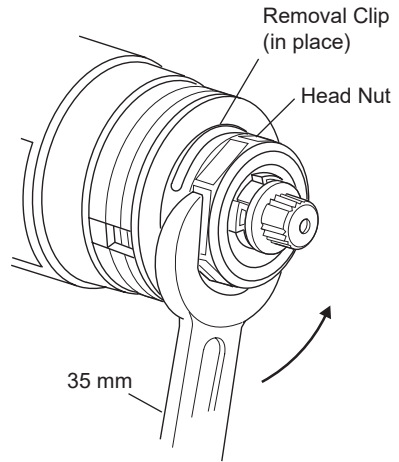

Note! On older models to assist with this process, orientate the cartridge so that the inlet seals are not directly aligned with the inlet ports, and carefully rotate the cartridge whilst pushing into the valve body until the cartridge lugs can be located in the body slots.

Note! The red markings on the cartridge will now not correspond with the body markings, so to avoid future confusion remove the red and blue stickers from the valve body.

6. Carefully align and then tighten the head nut; **do not overtighten** (max torque 2.5 N/m - 1.85 lbf ft).
7. Complete the installation (if appropriate).
8. If the mixing valve body has already been installed, restore the hot and cold supplies and check for any leaks.
9. Align and refit the body shroud and locking cap so that the markings will be visible to the user (built-in models: first refit the concealing plate).
10. The maximum temperature may now need resetting; check, and if necessary refer to section: '**Commissioning**'.

Rada 215 dk

1. Inlets are G3/4 B/DN20 compression, outlets are G1/2 B/DN15 compression. Flat faced union connections are recommended, so that the mixing valve body can be readily removed from its pipework for maintenance purposes.
If compression or other connections are used which do not allow ready removal of the mixing valve body then the integral strainer screens should be removed and supply-line strainers installed with a maximum mesh aperture of 0.25 mm.

Pipework and Flushing.

1. Run inlet and outlet pipework to the mixing valve, checking that hot and cold supplies have been piped to the correct inlets.
2. **Important! Flush through the hot and cold supplies thoroughly before connection to mixing valve.**
3. Connect the inlet and outlet pipework, checking that the hot and cold supplies have been piped to the correct inlets, and check all connections are watertight. Refer to section: '**Commissioning**'.

COMMISSIONING

Commissioning must be carried out in accordance with these instructions, and must be conducted by designated, qualified and competent personnel.

Exercising the Thermostat

Thermostatic mixing valves with wax thermostats are inclined to lose their responsiveness if not used. Mixing valves which have been in storage, installed but not commissioned, or simply not used for some time should be exercised before setting the maximum temperature or carrying out any tests.

A simple way to provide this exercise is:

- a) Make sure that hot and cold water are available at the valve inlets;
- b) Move the temperature control rapidly from cold to hot and hot back to cold several times, pausing at each extreme.

Maximum Temperature

The maximum blend temperature obtainable by the user should be limited, to prevent accidental selection of a temperature that is too hot.

All Rada thermostatic mixing valves are fully performance tested and the maximum temperature is preset to approximately 43°C under ideal installation conditions at the factory.

Site conditions and personal preference may dictate that the maximum temperature has to be reset following installation.

The mixing valves are provided with a locked cap to prevent unauthorised adjustment of the preset site temperature.

Maximum Temperature Setting

Check that an adequate supply of **hot** water is available at the hot inlet of the mixing valve.

The minimum temperature of the hot water must be at least 12°C above the desired blend, however during resetting this should be close to the typical storage maximum to offset the possibility of any blend shift due to fluctuating supply temperatures.

Check that both inlet isolating valves are fully open.

Temperatures should always be recorded using a thermometer with proven accuracy.

Resetting

1. Remove the locking screw using a 3 mm hexagonal key (supplied), and pull off the locking cap.
2. Pull off the temperature hub.
3. Rotate the spindle until the required maximum blend temperature is obtained at the discharge point (**clockwise = decrease temperature**).

When resistance is felt do not use force to turn any further, as this can damage the internal parts.

4. Once the desired maximum blend temperature is achieved, refit the hub without disturbing the spindle, positioning it so that the lug is between the stops on cartridge face (refer to illustration), so preventing any rotation. Check that the blend temperature has not altered.
5. Fit the locking cap, engaging the cap guides into the body slots, and secure with the locking screw.

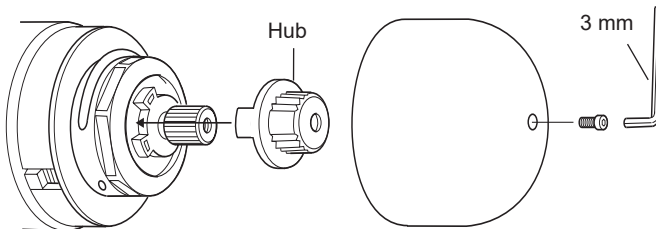

Locked Temperature Setting

Commissioning Checks

The following checks should be carried out following a cartridge replacement and whenever a mixing valve is introduced to, or returned to service.

(Temperatures should always be recorded with a thermometer with proven accuracy).

1. Check inlet pipework temperatures for correct function of checkvalves i.e. that hot water does not cross into cold supply and vice versa.
2. Check that the supply pressures are within the range of operating pressures for the valve.
3. All pipework and mixing valve connections are tight.
4. Adjust the temperature of the mixed water in accordance with the instructions (refer to **Maximum Temperature Setting**).

5. Operate the outlet flow control and check:
 - a) Flow rate is sufficient for purpose.
 - b) Temperature(s) obtainable are acceptable.
6. It is advisable to establish a performance check at this time, which should be noted for future reference as part of a Planned Maintenance Programme.
7. Carry out the following check:
 - a) the supply temperatures are within the range permitted for the valve and by guidance information on the prevention of legionella etc.
8. Carry out the following sequence:
 - a) record the temperature and pressure of the hot and cold water supplies.
 - b) record the temperature and flow rate of the mixed water at the largest draw-off flow rate.
 - c) record the temperature and flow rate of the mixed water at about the smallest draw-off flow rate.
 - d) isolate the cold water supply to the mixing valve and monitor the mixed water temperature.
 - e) isolate the hot water supply to the mixing valve and monitor the mixed water temperature.
 - f) record the maximum temperature achieved as a result of (d) and the final temperature.
 - g) record the date, equipment, thermometer etc. used for the measurements.

OPERATION

For models with locked temperature control, no user adjustment is intended.

An optional adjustable temperature knob is available as an accessory (408.89) which will allow user adjustable temperature control. Anti-clockwise rotation increases the temperature to the preset maximum. Clockwise rotation reduces the temperature to full cold.

Control of flow is via separate outlet valve(s), refer to section: '**Specifications**'.

FAULT DIAGNOSIS

Symptom	Cause / Rectification
1. Only hot or cold water from outlet.	<ul style="list-style-type: none"> a. Inlet supplies reversed (i.e. hot supply to cold inlet). Check. b. No hot water reaching Mixing Valve. Check. c. Check Strainers and inlet/outlet fittings for blockage. d. Refer to symptom 5 below. e. Supply conditions continuously outside operating parameters, refer to section: 'Specifications' and 2e below.
2. Fluctuating or reduced flow rate.	<p>Normal function of Mixing Valve when operating conditions are unsatisfactory.</p> <ul style="list-style-type: none"> a. Check Strainers and inlet/outlet fittings for flow restriction. b. Assure that minimum flow rate is sufficient for supply conditions. c. Make sure that dynamic inlet pressures are nominally balanced. d. Make sure that inlet temperature differentials are sufficient. e. Check thermostatic performance; renew Thermostatic Cartridge if necessary.
3. No flow from the Mixing Valve outlet.	<ul style="list-style-type: none"> a. Check Strainers and inlet/outlet fittings for blockage. b. Hot or cold supply failure; Thermostat holding correct shutdown function: rectify, and return to 2e above.
4. Blend temperature drift.	<p>Indicates operating conditions changed.</p> <ul style="list-style-type: none"> a. Refer to symptom 2 above. b. Hot supply temperature fluctuation. c. Supply pressure fluctuation.
5. Hot water in cold supply or vice versa.	<p>Indicates Checkvalves require maintenance, refer to section: 'Maintenance'.</p>
6. Maximum blend temperature setting too hot or too cool.	<ul style="list-style-type: none"> a. Indicates incorrect maximum temperature setting, refer to section: 'Commissioning'. b. As symptom 4 above. c. As symptom 5 above.
7. Water leaking from the Mixing Valve body.	<p>Seal(s) worn or damaged.</p> <ul style="list-style-type: none"> a. Obtain Service Pack (408 92), and renew all seals. b. If leak is from around the Temperature Spindle, renew the Thermostatic Cartridge.

MAINTENANCE

General

Maintenance of this product must be carried out in accordance with these instructions, and must be conducted by designated, qualified and competent personnel.

Rada products are precision-engineered and should give continued superior and safe performance, provided:

- 1. They are installed, commissioned, operated and maintained in accordance with the recommendations stated in this Product Manual.**
- 2. Periodic attention is given as necessary to maintain the product and its associated installation components in good functional order. Guidelines are given below.**

All the mixing valves in this series have all functional parts contained within service-free cartridges, so any maintenance requirement is reduced to temperature, performance and functional checks and inspection, with cartridge renewal when necessary. In larger installations with a number of mixing valves, it is good policy to maintain a small stock of spare cartridges so that no mixing valve or facility need be out of commission for more than the time it takes to exchange the cartridge, and also, eventually, a rolling programme of cartridge renewal can be undertaken as part of a planned maintenance procedure.

Planned Maintenance Programmes (preventative/precautionary maintenance)

1. It is recommended that a routine of preventative maintenance be employed which is based upon assessment of the risks to the user. The following practices are intended to support such a routine:
 - In-service tests
 - Regular temperature checking in between In-service tests
 - Maintenance of a log of in-service tests and temperature checks together with details of cartridge replacements and any other service work.
2. Thermostatic mixing valves only operate correctly when all components have been serviced and have been tested for correct performance. If any component is faulty, including the thermostat, the mixing valve will not operate correctly and could allow full hot water to pass through the mixing valve.
3. As with all other thermostatic mixing valves, the critical sensing element in the Rada 215 together with other "critical components" will exhibit wear over a period of time and usage. All of these parts are contained within the thermostatic cartridge.

Critical Components

The following must be replaced at least every 5 years.

408.99	Thermostatic Cartridge Assembly, 215 Series
408.68	Checkvalve Cartridge; 215 dk/oemk
408.75	Checkvalve Cartridge; 215 bk
408.91	Strainer Pack; 215 series
147.67	Checkvalve Insert Pack 215 dk/bk

4. Cartridge & Checkvalve Replacement

- The designed minimum service life of thermostatic cartridge and checkvalve is five years providing the Rada 215 is operated with the recommended operating conditions and within the recommended operating parameters.

Therefore under these normal conditions and /or parameters it is recommended that the cartridge and checkvalve be replaced every five years.

However when supply conditions and/or usage patterns do not conform to the recommended conditions and/or parameters the cartridge and checkvalve may need to be changed more frequently, "recommended operating conditions" and "recommended parameters" are defined in section: **'Specifications'**.

- Should an internal malfunction occur then this will probably require cartridge and checkvalve renewal The thermostatic and checkvalve cartridges contain no user-serviceable parts, and must not be dismantled. Components are precision-made, so care must be taken while servicing to avoid damage.
- The three 'O' seals located on the outside diameter of the Rada 215 cartridge are static seals. During the operation of the mixing valve these seals are not exposed to the wear and tear associated with 'dynamic' seals. In fact there is no movement within these seals during the operation of the thermostatic unit. The above mentioned inlet 'O' seals should only be replaced when the cartridge and checkvalve is replaced, or when the 'O' seals have been damaged through abnormal treatment. Under normal circumstances the thermostatic cartridge should not need to be removed from the mixing valve body every 12 months as it is a 'service-free' cartridge.
- Monitoring the performance of the mixing valves as per Australian Standard AS 4032.3 is also recommended. This will make sure that the cartridges (complete with seals) and checkvalves are replaced at suitable periods to facilitate preventative maintenance.

In-Service Tests

The principle means for determining the continued satisfactory performance of the mixing valve is the in-service test.

The in-service test procedure should be carried out at both 6 to 8 weeks and 12 to 15 weeks after commissioning the valve. The results of these tests are used to determine when, after initial commissioning, the in-service test is next repeated.

Frequency of In-Service tests

The in-service test results over the first 28 weeks after commissioning determine the ongoing frequency of testing shown in the right hand boxes of the Guide.

Whenever a thermostatic cartridge is replaced the in-service test frequency should be re-assessed as if it was a new valve.

Note! In-service tests should be carried out with a frequency which identifies a need for service work before an unsafe water temperature can result.

The general principle to be observed after the first 2 or 3 in-service tests is that intervals of future tests should be set to those which previous tests have shown can be achieved with no more than a small change in mixed water temperature. But in no case longer than 12 months.

Temperature Testing (In between In-Service Tests)

Check and record warm water temperature regularly to confirm correct operating performance of the valve. In health care applications such as hospitals, aged persons facility, nursing homes etc. such checks must be made at least every month. More regular temperature checks should be made where increased risks are perceived such as where patients are unable to immediately respond to an increase in water temperature by either shutting the water off or removing themselves from the contact with the water. Records of warm water temperature checks should be included in a log book.

Thermostatic Mixing Valve Performance Records (Log Book)

It is recommended that the user maintains a log of the in-service tests described herein, together with a record of any service work carried out and the replacement of critical components. It is also recommended that any maintenance personnel sign the user log in respect of all thermostatic mixing valves examined on each attendance at the user's premises.

Recommended Content of Maintenance Log

It is recommended that the Maintenance Log should record the following:

Details of valve, location and use, risk level and instructions

Valve make, model and unique identification number

Valve location

Date installed

Application i.e. type of discharge: bath, shower etc.

Risk assessment report number

Risk level found (e.g. vulnerability of patient)
Frequency of critical component replacement
Frequency of temperature monitoring
Responsibility for temperature monitoring
Location of temperature monitoring records
Source of spares and advice
Issue number of Product Manual

Details of in-service testing and maintenance

Initial commissioning test data (Supply pressures and temperatures, mixed water temperature, flow rate, result of cold water isolation test, date carried out, signature of maintenance person).

First in-service test due date

First in-service test data (As for initial commissioning)

Details of any remedial work carried out to valve or supply system

Second in-service test due date

Second in-service test data (As for initial commissioning)

Details of any remedial work, including part replacement, carried out to valve or supply system.

Next in-service test due date

Next in-service test data (As for initial commissioning)

Details of any remedial work, including part replacement, carried out to valve or supply system

Note! Local requirements may demand that additional information be recorded

In-Service Test Procedure

In-Service Tests should be carried out 6 to 8 weeks, and 12 to 15 weeks after commissioning the valve. The results of these tests will determine how frequently further testing is to be carried out.

Testing that is carried out, is to determine the difference between the current blend temperature and the temperature recorded previously at commissioning or at previous in-service test e.g. $43^{\circ}\text{C} - 42.5^{\circ}\text{C} = 0.5^{\circ}\text{C}$.

1. Measure and record the supply temperature.
2. Measure and record the supply pressure if possible (see Commissioning).
3. Measure and record the blend temperature with one outlet flowing at approximately lowest draw-off normal flow rate. **Compare to previously recorded temperature at that flow rate. Record difference e.g. 1°C or 0.5°C etc.**
4. Measure and record blend temperature with all outlets that are likely to be operating at the same time, flowing at normal flow rate. **Compare to previously recorded temperature at that flow rate. Record difference e.g. 1°C or 0.5°C etc.**

5. If blend water temperature has changed by more than 1°C, carry out the following tasks or if the change is less than 1°C move directly to item 6.
 - Inspect and clean/replace strainers if necessary.
 - Verify that the check valves are not allowing hot water to by-pass through the valve to the cold inlet supply and vice versa.
 - Make sure that the isolating valves are fully open.
 - Reset and record blend temperature as per commissioning instructions.
6. At this stage ensure that the supply temperatures/pressures and the flow rates during test are within the specification parameters of the mixing valve. Then record the figures.
7. Carry out thermal shut down by isolating the cold water inlet supply. The mixing valve should shut down the flow of outlet water. Measure and record the temperature of any drainage water i.e. maximum temperature immediately after shut down and final temperature of any drainage water. Normally the flow of any drainage water will stop immediately unless the dead leg from the mixing valve is too long.
8. **Is the final drainage water temperature more than 2°C above the temperature recorded at the previous in-service test. If it is, replace the thermostatic cartridge.**
9. If the thermostatic cartridge is replaced carry out the commissioning procedure.

Frequency Of In-Service Tests

Follow the procedure detailed in the "In Service Test Procedure". This procedure must be carried out at 6 to 8 weeks and 12 to 15 weeks after commissioning.

The first 2 to 3 In-Service Test results should be used as a guide, and in conjunction with a suitable risk assessment, to determine the schedule of future In-Service Tests.

Result of 6 - 8 Week Test	Result of 12 - 15 Week Test	Next In-Service Test Interval
Less than or equal to 1°C	Less than or equal to 1°C	9 - 12 Weeks
More than 1°C	Less than or equal to 1°C	9 - 12 Weeks
Less than or equal to 1°C	Less than 1°C	9 - 12 Weeks
More than 1°C	Less than 1°C	6 - 9 Weeks

Training

Maintenance personnel should also make sure that the user's staff are aware of the importance of reporting temperature variations and that when detected, these should be recorded in the log.

Maintenance Procedures

Maintenance must be carried out in accordance with these instructions, and must be conducted by designated, qualified and competent personnel.

This mixing valve series is designed for minimal maintenance under conditions of normal use.

External surfaces may be wiped clean with a soft cloth, and if necessary, a mild washing-up type detergent or soap solution can be used.

Caution! Many household and industrial cleaning products contain mild abrasives and chemical concentrates, and should not be used on polished, chromed or plastic surfaces.

When ordering spare parts, please state product type and identify part name and number (refer to section: '**Spare Parts**'). A service pack is available, containing all the seals and strainer screens that may be necessary for renewal during maintenance or servicing (part no. 408 92).

Lubricants

Important: Use silicone-only based lubricants on this product. Do not use oil-based or other lubricant types as these may cause rapid deterioration of Seals.

Standard silicone-only based lubricants may be used on all static seals, and threads, to assist refitting (e.g. Rocol MX22).

Thermostatic Cartridge

Removal

1. Isolate the supplies to the mixing valve, and open an outlet fitting to release pressure and to assist the draining of residual water.
2. Unscrew the locking cap screw using a 3 mm hexagonal key (supplied) and remove the locking cap.

Note! Do not remove the temperature hub.

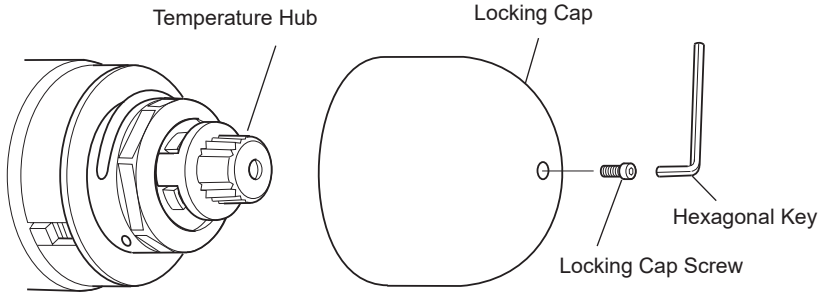

3. With the removal clip still in place, unscrew the head nut fully using a 35 mm A/F wrench. Note which inlet aligns with the hot (marked H and red) lug on cartridge and pull the thermostatic cartridge free from the valve body.

Caution! Some residual water may be released.

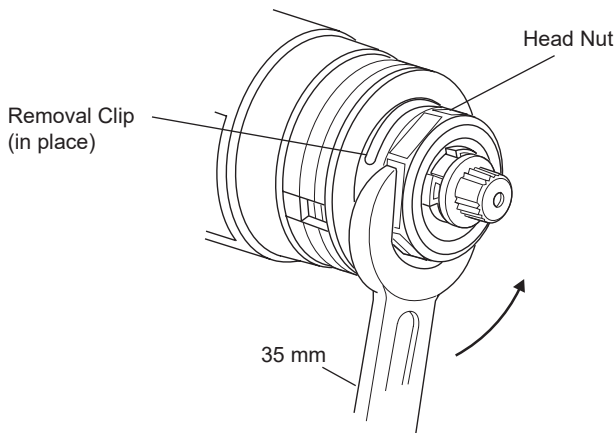

Thermostatic Cartridge Removal

Cleaning/Renewal of Parts

- The interior surface of the mixing valve body must be clean before refitting cartridge. If scale or deposition is present clean **(without checkvalve cartridges fitted)** using a mild proprietary inhibited scale solvent, e.g. domestic kettle descaler. After descaling, rinse valve interior thoroughly in clean water before refitting cartridges.

Note! The body interior must be cleaned carefully and not damaged in any way. Do not use any abrasive material.

- Cartridges may only be cleaned by flushing through under a jet of clean water to remove lodged particles.

Do not descale. Cartridges are not serviceable, and must not be dismantled.

Cartridges cannot be tested individually, service condition should be assessed as part of the performance check; refer **Commissioning Checks**.

- When renewing the thermostatic cartridge, retain the removal clip and head nut off the displaced unit and refit.
- Examine all accessible seals for signs of deformation or damage, and renew as necessary, taking care not to damage seal grooves (a service pack is available, containing all seals and strainer screens that may be necessary for renewal during maintenance or servicing, part no. 408.91/92). If the strainer screens need replacing, a strainer screen pack is available.
- Lightly coat all seals with a **silicone-only based lubricant** to assist re-assembly (see **Lubricants**).
- Identify which is the hot inlet to the mixing valve body, and align the thermostatic cartridge accordingly. Make sure that the cartridge inlet seals are greased and carefully push the thermostatic cartridge back into the mixing valve body, checking that the 2 cartridge inlet seals remain in place, and locate the cartridge lugs into the body slots.

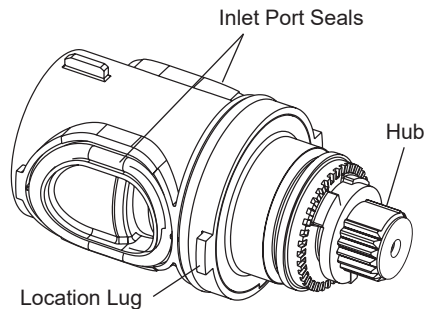

- Note!** On older models to assist with this process, orientate the cartridge so that the inlet seals are not directly aligned with the inlet ports, and carefully rotate the cartridge whilst pushing into the valve body until the cartridge lugs can be located in the body slots.
- Carefully align and then tighten the head nut; **do not overtighten** (max. torque 2.5 N/m = 1.85 lbf. ft).
(Built-in models: refit the concealing plate).
 - Align and refit the body shroud and locking cap so that the markings will be visible to the user.
 - Restore the hot and cold supplies and check for any leaks.
 - Carry out the commissioning checks; refer to section: '**Commissioning**'.

Checkvalve Cartridges

Hot water entering the cold supply, or vice versa, indicates that immediate attention is necessary. This is carried out by removing and cleaning, or renewing as necessary, the two checkvalve cartridges.

1. Isolate the supplies to the mixing valve, and open an outlet fitting to release pressure and to assist the draining of residual water.
2. Location and removal of checkvalve cartridges varies according to the mixing valve model:

215 bk; The checkvalve cartridges are located in each elbow. To remove, first remove the locking knob. Then undo the checkvalve cartridge head hexagon using a 12 mm A/F hexagonal key and pull free.

Caution! Some residual water may be released at this point.

215 dk/oemk; The checkvalve cartridges are located at the mixing valve body inlets. To remove, first release the mixing valve body from the inlet and outlet connectors, then release the checkvalve cartridges using a 30 mm A/F wrench.

Caution! Some residual water may be released at this point.

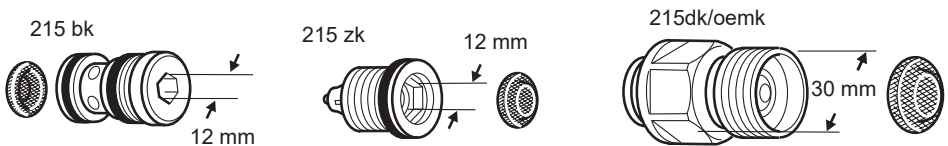

3. The checkvalve cartridge assembly may be cleaned by removal of the inlet strainers, and flushing through under a jet of water to remove lodged particles.

The checkvalve cartridge is not a serviceable item, so any functional failure or damage will require its renewal.

Lightly wipe external seals and thread with a **silicone-only based lubricant** to assist refitting. Re-assembly into the mixing valve is a reversal of the above procedures. Do **not overtighten** when re-inserting cartridges. Restore the water supplies and check for leaks.

Inlet Strainers

Blockage of the inlet strainer screens can lead to poor flow performance and reduced temperature control. It is essential that the inlet strainer screens are cleaned or, if necessary, renewed at least annually.

A strainer pack is available for all 215 series models (408 91) containing 2 strainer screens and all the seals (plus lubricant) and nylon washers which may need to be renewed during strainer inspection (see component matrix).

1. Isolate the supplies to the mixing valve, and open an outlet fitting to release pressure and to assist the draining of residual water.
2. The strainer screens are located at the inlet of each checkvalve cartridge. To access the inlet strainer screens:
215 bk; remove the checkvalve cartridges as described in the previous section.
215 dk, 215 oemk; remove the mixing valve body from its pipework connections.
3. The strainer screens are dished outwards and are a push-fit into the housing. Remove carefully, using a sharp-pointed implement.
4. The strainer screens may be cleaned under a jet of water, or renewed.
5. Re-assembly into the mixing valve is a reversal of the above procedures. Do not overtighten when re-inserting cartridges.
6. Restore the water supplies and check for leaks.

Elbow/Body Seals

Some models have inlet/outlet adaptor, elbow and elbow adaptor seals which are static and should rarely require renewal. These seals are included in the service pack (408 92).

1. Isolate the supplies to the mixing valve, and open an outlet fitting to release pressure and to assist the draining of residual water.
2. Release inlet and outlet connections. B models: the mixing valve body will require removal from recess or panel mountings, refer to section: '**Installation Procedures**'.
3. Remove the elbows by loosening each elbow grubscrew using a 2.5 mm wrench key (supplied).
4. Remove the adaptors using a 12 mm hexagonal key.
5. Lightly coat seals with a silicone-only based lubricant to assist re-assembly.
6. When re-inserting adaptors, do not overtighten.
7. Refit and remake pipework connections, restore hot and cold supplies and check for any leaks.

SPARE PARTS

147.67	Checkvalve Insert Pack 215 dk/bk
407.26	Removal Clip
407.28	Hub, Black
407.54	Locking Cap; 215 series
407.61	Body; 215 bk/oemk
407.62	Body; 215 dk
407.64	Head Nut; 215 series
407.75	Elbow Adaptor, 215 bk (2)
407.88	Mounting Bracket; 215 bk
407.92	Building-in Shroud; 215 bk
407.96	Foam Seal; 215 bk
408.57	Elbow RH; 215 bk
408.58	Elbow LH; 215 bk
408.68	Checkvalve Cartridge; 215 dk/oemk (2)
408.69	Inlet/Outlet Adaptor; 215 bk/oemk
408.74 •	Component Pack; 215 bk
408.75	Checkvalve Cartridge; 215 bk (2)
408.76	Concealing Plate Assembly; 215 bk
408.77 •	Concealing Plate Bracket Assembly; 215 bk
408.78 •	Bracket Component Pack; 215 bk
408.91 •	Strainer Pack; 215 series
408.92	Service Pack; 215 series
408.99	Thermostatic Cartridge Assembly, 215 Series
575.09	Wrench Key, 3 mm
575.12 †*	Wrench Key, 2.5 mm; 215 bk/oemk
611.72	Locking Screw, uses 3 mm wrench key
631.61 •	'O' seal
983.07	Lubricant Sachet

* Included in 215 Service Pack 408 92

† Included in 215 Strainer Pack 408 91

• These spares are supplied with a sachet of lubricant.

All spare parts listed above are supplied singly. Figures in brackets denote quantity used on mixer model. Kohler Mira has a policy of continual product development and parts illustrated may not be identical to those supplied.

215 bk

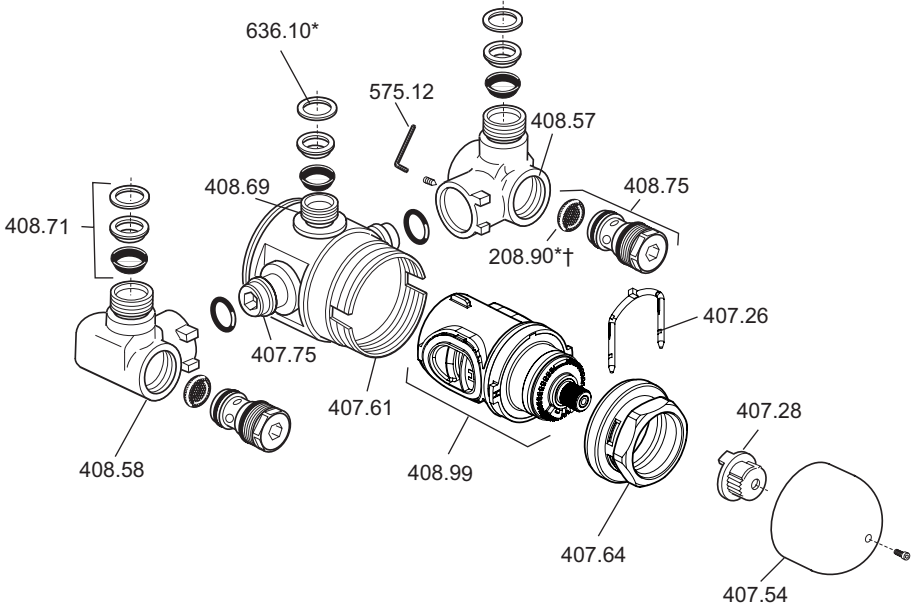

215 dk

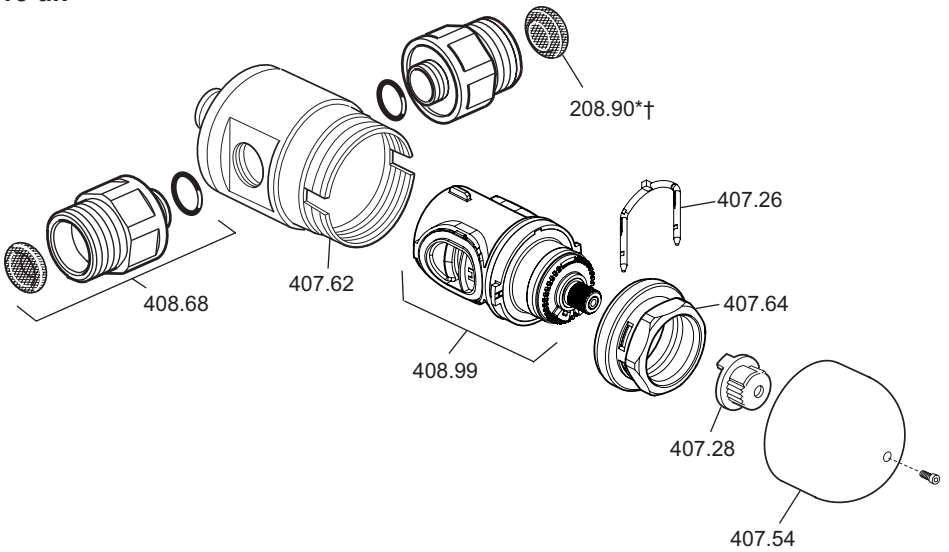

Rada 215 series: Strainer and Service Packs component matrix

Part Ref.	Qty	Part No.	Component	215zk	215bk	215dk/ oemk
408 91 Strainer Pack	2x	208 90	Strainer Screen	2	2	2
	4x	630 59	Seal		4	
	3x	636 10	Nylon Washer (15 mm)			1
	2x	636 11	Nylon Washer (22 mm)	2		2
	1x	983 07	Lubricant	1	1	1
408 92 Service Pack	2x	208 90	Strainer Screen	2	2	2
	2x	1617 143	Inlet Seal	2	2	2
	1x	407 46	Seal	1	1	1
	1x	408 19	Lip-Seal Outlet			
	1x	611 72	locking Screw	1	1	1
	2x	618 22	Grubscrew	2	2	
	1x	630 13	Seal			
	2x	630 41	Seal	2	2	
	4x	630 59	Seal	2	4	
	5x	631 61	Seal	3	3	2
	3x	636 10	Nylon Washer (15 mm)			1
	2x	636 11	Nylon Washer (22 mm)	2		2
	1x	983 07	Lubricant	1	1	1
408.89	1x		Knob	1	1	1
Temperature Knob Assy	1x		Screw	1	1	1
	1x		Body Shroud	1	1	1

PRODUCT WARRANTY

For full details of our product warranty please refer to our warranty document available upon request or on our website www.thornthwaite.com.au

CUSTOMER CARE

Guarantee

Your product has the benefit of our manufacture's guarantee which starts from date of purchase. Within the guarantee period we will resolve defects in materials or workmanship, free of charge, by repairing or replacing parts or product as we may choose.

This guarantee is in addition to your statutory rights and is subject to the following conditions:

- The product must be installed and maintained in accordance with the instructions given in this user guide.
- Servicing must only be undertaken by us or our appointed representative. **Note!** If a service visit is required the product must be fully installed and connected to services.
- Repair under this guarantee does not extend the original expiry date. The guarantee on any replacement parts or product ends at the original expiry date.
- For shower fittings or consumable items we reserve the right to supply replacement parts only.

The guarantee does not cover:

- Call out charges for non product faults (such as damage or performance issues arising from incorrect installation, improper use, inappropriate cleaning, lack of maintenance, build up of limescale, frost damage, chemical attack, corrosion, system debris or blocked filters) or where no fault has been found with the product.
- Water or electrical supply, waste and isolation issues.
- Compensation for loss of use of the product or consequential or indirect loss of any kind.
- Damage or defects caused if the product is repaired or modified by persons not authorised by us or our appointed representative.
- Routine maintenance or replacement parts to comply with the requirements of the TMV2 or TMV3 healthcare schemes
- Accidental or wilful damage.
- Products purchased ex-showroom display.

What to do if something goes wrong

If your product does not work correctly refer to this manual for fault diagnosis and check that it is installed and commissioned in accordance with our instructions. If this does not resolve the issue, contact us for help and advice.



Technical Helpdesk Service

Contact our Customer Services Team for product advice, to purchase spare parts or accessories or to set up service visit. You can contact us via phone or e-mail - contact details below. Please provide your model name, power rating (if applicable) and date of purchase.



Rada Website (www.radacontrols.com)

From our website you can view our full product catalogue or download a brochure.



Spares and Accessories

We hold the largest stocks of genuine Rada spares and accessories.



Service/Repairs

No one knows our products better than our nationwide team of Service Technicians. We can carry out service or repair work to your product both during and after the guarantee period. You have the assurance of a fully trained Technician, genuine Rada spare parts and a 12 month guarantee on any chargeable work done.

Service Contracts

Regular servicing ensures your product continues to operate at the peak of performance. We offer annual or bi-annual servicing carried out by our fully trained technicians subject to site survey

To Contact Us - UK Customer Service & Specification Enquiries
Australian Contact:

For full details of the Australian product warranty please refer to our warranty document available upon request or on our website www.thornthwaite.com.au

Australian Contact:

Thornthwaite Technologies Pty Ltd
Ph. +61 02 9417 4466
info@thornthwaite.com.au
www.thornthwaite.com.au

New Zealand Contact:

AL Byrne Waterways
Ph. + 64 09 623 0650
sales@waterways.net.nz
www.waterways.net.nz

Rada is a registered trade mark of Kohler Mira Limited.

The company reserves the right to alter product specifications without notice.



rada